

**TECHNICAL MANUAL**

**DIRECT SUPPORT AND GENERAL SUPPORT  
MAINTENANCE OR AVIATION INTERMEDIATE  
MAINTENANCE (AVIM) MANUAL**

**BLADE ANTENNA AS-2285/ARC  
(NSN 5821-00-054-6374)**

**AND**

**BLADE ANTENNA AS-2285/ARC  
(NSN 5821-01-003-0632)**

---

**HEADQUARTERS, DEPARTMENT OF THE ARMY**

**17 MARCH 1982**

### **WARNING**

Be extremely careful when working around the antenna or the antenna terminals. RADIO FREQUENCY HIGH VOLTAGES EXIST AT THE TERMINALS. Operator and maintenance personnel should be familiar with the requirements of TB SIG 291 before attempting installation or operation of the equipment covered in this manual. Failure to follow requirements of TB SIG 291 could result in injury or DEATH.

### **CAUTION**

The coupler unit in the AS-2285/ARC contains transistorized circuits. To avoid transistor damage always disconnect the equipment from the power source when making cable connections. Check the battery voltage before making connections. TRANSISTORS AND PRINTED CIRCUITRY MAY BE PERMANENTLY DAMAGED BY IMPROPER VOLTAGE. 5 SAFETY STEPS TO FOLLOW IF SOMEONE IS THE VICTIM OF ELECTRICAL SHOCK

- 1) DO NOT TRY TO PULL OR GRAB THE INDIVIDUAL
- 2) IF POSSIBLE, TURN OFF THE ELECTRICAL POWER
- 3) IF YOU CANNOT TURN OFF THE ELECTRICAL POWER, PULL, PUSH, OR LIFT THE PERSON TO SAFETY USING A WOODEN POLE OR A ROPE OR SOME OTHER INSULATING MATERIAL
- 4) SEND FOR HELP AS SOON AS POSSIBLE
- 5) AFTER THE INJURED PERSON IS FREE OF CONTACT WITH THE SOURCE OF ELECTRICAL SHOCK, MOVE THE PERSON A SHORT DISTANCE AWAY AND IMMEDIATELY START ARTIFICIAL RESUSCITATION

**DIRECT SUPPORT AND GENERAL SUPPORT MAINTENANCE OR AVIATION  
INTERMEDIATE MAINTENANE (AVIM) MANUAL**

**BLADE ANTENNA AS-2285/ARC (NSN 5821-00-054-6374)  
AND  
BLADE ANTENNA AS-2285A/ARC (NSN 5821-01-003-0632)**

**REPORTING ERRORS AND RECOMMENDING IMPROVEMENTS**

You can help improve this manual. If you find any mistakes or if you know of a way to improve the procedures, please let us know. Mail your letter, DA Form 2028 (Recommended Changes to Publications and Blank Forms), or DA Form 2028-2, located in the back of this manual direct to: Commander, US Army Communications - Electronics Command, ATTN: DRSEL-ME-MQ, Fort Monmouth, NJ 07703.

In either case a reply will be furnished direct to you.

		Paragraph	Page
CHAPTER 1	INTRODUCTION		
	Scope .....	1-1	1-1
	Index of Publications. ....	1-2	1-1
	Maintenance Forms, Records and Reports .....	1-3	1-1
	Reporting Equipment Improvement Recommendations (EIR) .....	1-4	1-1
	Administrative Storage. ....	1-5	1-1
	Destruction of Army Electronics Materiel .....	1-6	1-1
	Use of Term Hertz .....	1-7	1-1
	Historical Revisions to Equipment .....	1-8	1-2
CHAPTER 2	FUNCTIONING OF EQUIPMENT		
Section I.	Block Diagram Analysis		
	Purpose and Use.....	2-1	2-1
	General.....	2-2	2-1
	Block Diagram Analysis.....	2-3	2-1
Section II.	Schematic Diagram Analysis		
	Phase Discriminator Analysis .....	2-4	2-2
	Operational Amplifier Analysis .....	2-5	2-3
	Servo Rotation Logic Circuits Analysis .....	2-6	2-6
	Sequential Pulsing Logic Analysis .....	2-7	2-6
	Servo Motor Sequencing Logic Analysis .....	2-8	2-6
	Servo Motor and Motor Control Analysis .....	2-9	2-8
	Fine Tune Circuit Analysis .....	2-10	2-8
	Transmit/Receive Circuit Analysis .....	2-11	2-9
	Homing Logic Analysis .....	2-12	2-9
	Manual Override Logic Analysis .....	2-13	2-9
	Antenna Circuit Analysis .....	2-14	2-10
	Power Sources Analysis .....	2-15	2-10
	Tuning Indicator Drive Analysis .....	2-16	2-10

**\*This manual supersedes-d TM 11-5821-284-35, 9 April 1971.**

		Paragraph	Page
CHAPTER 3	DIRECT SUPPORT MAINTENANCE		
Section I.	General		
	Scope of Direct Support Maintenance .....	3-1	3-1
	Tools, Test Equipment and Materials Required .....	3-2	3-1
Section II.	Direct Support Troubleshooting		
	Troubleshooting Procedure .....	3-3	3-1
	General Precautions .....	3-4	3-2
	Antenna Troubleshooting .....	3-5	3-2
Section III.	Direct Support Repair and Replacement		
	General .....	3-6	-
	Separation of Radome Assembly A2 and Coupler Assembly A1 .....	3-7	-
	Reassembly of Coupler Assembly A1 and Radome Assembly A2 .....	3-8	3-3
Section IV.	Direct Support Testing Procedures		
	General .....	3-9	3-3
	Special Requirements .....	3-10	3-3
	Physical Tests and Inspection .....	3-11	3-3
	Antenna VSWR Test .....	3-12	3-3
	Manual Cycle and Run Signal Test .....	3-13	3-4
CHAPTER 4	GENERAL SUPPORT MAINTENANCE		
Section I.	General		
	Scope of General Support Maintenance .....	4-1	4-1
	Test Equipment and Addition Equipment Required .....	4-2	4-1
	General Precautions .....	4-3	4-1
	Troubleshooting Procedures .....	4-4	4-1
	Troubleshooting Chart .....	4-5	4-2
Section II.	General Support Repair and Replacement		
	General .....	4-6	4-6
	Disassembly of Coupler Assembly .....	4-7	4-6
	Assembly of Coupler Assembly .....	4-8	-
CHAPTER 5	PERFORMANCE STANDARDS		
	Applicability of Performance Standards .....	5-1	5-1
	Applicable References .....	5-2	5-1
	Test Facilities Required .....	5-3	5-1
	Phase Discriminator Output Test.....	5-4	5-1
	Servo Loop Test .....	5-5	5-2
	Fine Tune Mode Test .....	5-6	5-2
	Servo Gain Test.....	5-7	5-3
	Receive/Transmit Logic Test .....	5-8	5-3
	Homing Circuit Test .....	5-9	5-4
	Power Supply Test .....	5-10	5-4
	Pulsing Circuit Test .....	5-11	5-5
	Sequencing circuit Test .....	5-12	5-5
	Manual Override Circuit Test .....	5-13	5-7
CHAPTER 6	FINAL ILLUSTRATIONS		6-1
APPENDIX A	REFERENCES .....		A-1

**List of Illustrations**

Figure	<i>Title</i>	<i>Page</i>
2-1	Antenna AS/2285/ARC, vhf/fm blade type, functional block diagram	2-3
2-2	Phase discriminator, simplified schematic diagram .....	2-4
2-3	Phase discriminator, vector analysis diagram .....	2-4
2-4	Operational amplifier, simplified schematic diagram .....	2-5
2-5	Servo rotation logic, simplified schematic diagram .....	2-5
2-6	Sequential pulsing logic simplified schematic diagram .....	2-7
2-7	Servo motor sequencing logic, simplified schematic diagram .....	2-7
2-8	Servo motor and motor control logic, simplified schematic diagram .....	2-10
	logic, simplified schematic diagram .....	2-11
2-9	Transmit/receive logic, homing logic, and manual override	
3-1	Test connections, antenna VSWR test .....	3-5
3-2	Test connections, manual cycle and run signal test .....	3-5
4-1	Gear train assembly A3, exploded view	
5-1	Test connections, phase discriminator output test .....	5-3
5-2	Test connections, servo loop test.....	5-4

## List of Illustrations (con't.)

Figure	Title	Page
5-3	Test connections, receive/transmit logic test .....	5-5
5-4	Test connections, power supply test .....	5-5
5-5	Test connections, sequencing circuit test .....	5-8
5-6(1)	437S-1/IA/IC Coupler assembly test points (sheet 1 of 2) .....	5-9
5-6(2)	437S-1/ IA/IC Coupler assembly test points (sheet 2 of 2) .....	5-9
5-7	437S-1/IA/1C Coupler connection J2 test points .....	5-10
5-8	Servoamplifier circuit board A I test points .....	5-11
5-9	A1A1 through A1A6 flat pack test points .....	5-12
5-10	Operational amplifier AIARI test points .....	5-12
FO-6-1	Color code marking for MIL-STD resistors, inductor-, and capacitors schematic diagram.	Located in back of Manual
FO-6-2 (1)	AS-2285/ARC and AS-2285A/ARC vhf/fm blade antenna (Models 437S-1, -1A, -C),	
FO-6-2 (2)	AS-2285/ARC and AS-2285A/ARC vhf/fm blade antenna (models 437S-1, -1A, -1C), schematic diagram	
FO-6-3 (1)	AS-2285/ARC and AS-2285A/ARC vhf/fm blade antenna (models 437S-1B), schematic diagram	
FO-6-3 (2)	AS-2285/ARC vhf/fm blade antenna (model 437S-1B), schematic diagram	
FO-6-4	AS-2285/ARC and AS-2285A/ARC vhf/fm blade antenna, waveforms	
FO-6-5	Radome and coupler assembly, exploded view	
FO-6-6	Coupler assembly A1, exploded view	

**CHAPTER 1  
INTRODUCTION**

**1-1. Scope**

a. This manual covers direct support (DS) and general support (GS) maintenance, or Aviation Intermediate Maintenance (AVIM), for Blade Antenna AS-2285/ARC and AS-2285A/ARC (antenna). It includes instructions appropriate to DS and Gs (AVIM) maintenance categories for the troubleshooting, testing, and repairing of the antenna and the replacement of maintenance parts. Detailed functioning of the antenna is covered in chapter 2 of this manual. The manual also lists tools, materials, and test equipment required for DS and GS (AVIM) maintenance.

b. Operating instructions and organizational maintenance for the antenna are contained in TM 11-5821-284-20. Detailed information pertaining to functioning and DS and GS (AVIM) maintenance of auxiliary items of equipment used with the antenna is contained in technical manuals with a system using the antenna (appx A).

c. Different models of the antenna (437S-1, 1A, 1B, and 1C) are similar in purpose, operation, and appearance. The AS-2285/ARC includes models 437S-1, 1A, and 1B; the AS-2285A/ARC includes model 437-1C. Some models include higher power handling capabilities and a manual tuning circuit. Refer to paragraph 1-9 of TM 11-5821-284-20 for differences in models.

**1-2. Index of Publications**

Refer to the latest issue of DA Pam 310-4 to determine whether there are new editions, changes, additional publications, or modification work orders pertaining to the equipment.

**1-3. Maintenance Forms, Records, and Reports**

a. *Reports of Maintenance and Unsatisfactory Equipment.* Department of the Army forms and procedures used for equipment maintenance will be those prescribed by TM 38-750, the Army Maintenance Management System.

b. *Report of Item and Packaging Deficiencies.* Fill out and forward SF 364 (Report of Discrepancy

(ROD)) as prescribed in AR 735-11-2/DLAR 4140-55/NAVSUPINST 4440.127E/AFR 400 54/MCO 4430 E

c. *Discrepancy In Shipment Report (DISREP) (SF 361).* Fill out and forward Discrepancy in Shipment Report (SF 361) as prescribed in AR 55-38/NAVSUPINST 4610.33B/AFR 75-18/MCO P4610.19C and DLAR 4500.15.

**1-4. Reporting Equipment Improvement Recommendations (EIR)**

If your blade antenna needs Improvement, let us know. Send us an EIR. You, the user, are the only one who can tell us what you don't like about your equipment. Let us know why you don't like the design. Tell us why a procedure is hard to perform. Put it on SF 368 (Quality Deficiency Report). Mail it to Commander, US Army Communications-Electronics Command, ATTN. DRSEL-ME-MQ, Fort Monmouth, New Jersey 07703. We'll send you a reply.

**1-5. Administrative Storage**

Administrative storage of equipment issued to and used by Army activities will have preventive maintenance performed in accordance with the PMCS charts before storing. When removing the equipment from administrative storage the PMCS should be performed to assure operational readiness. Disassembly and repacking of equipment for shipment or limited storage are covered in paragraphs 4-4 through 4-7 for TM11-5821-284-20.

**1-6. Destruction of Army Electronics Materiel**

Destruction of Army electronics materiel to prevent enemy use shall be in accordance with TM 750-244-2.

**1-7. Use of Term Herz**

The National Bureau of Standards has officially adopted the term Hertz (Hz) to replace cycles per second (cps). The chart below provides the common equivalents of the unit/quantity terms. The term Hertz is used throughout this manual except where equipment markings or decals reflect the old term.

Unit/quantity	Old term	Old abbreviation	New term	New abbreviation
Frequency	Cycles per second	cps	Hertz-	Hz
10 <sup>3</sup> cycles per second	Kilocycles per second	kc	Kilohertz-	kHz
10 <sup>6</sup> cycles per second	Megacycles per second	Mc	Megahertz-	MHz
10 <sup>12</sup> cycles per second	Gigacycles per second	Gc	Gigahertz-	GHz

**1-8. Historical Revisions to Equipment**

a. No external appearance or major operational differences exist between procurements of antenna AS 2285/ARC

b. The electrical subassemblies of antenna AS 2285/ARC have been revised during the history of antenna AS-2285/ARC as indicated in the table below.

*MNC EFFECTIVITY LISTING*

Ref des	MCN effectivity	Description of change
A1CR10	101	Changed to 1N748A
A1CR25	101	Deleted and substituted insulated bus wire
A1CR28	101	Changed to 1N746A
A1R16	101	Changed to 2 7K, 1/4 watt
A1R28	101	Changed to 560K, 1/4 watt
A2R1	101	Changed to 10 ohm, 1/4 watt
A2R4	101	Changed to 680 ohm, 1/4 watt
A2R5	101	Changed to 390 ohm, 1/4 watt
Gear A, gear B, shaft bearings and spacers	101	Changed gear A from steel to aluminum, and shaft from 1/8" diameter interchangeable with older models If all parts are ordered
Plate, shunt Inductor L4	101	Changed width of plate to improve vswr performance
Radome	101	Changed element shape to improve vswr performance
A1R5	200 (approx)	Changed t6 51K, 1/4 watt 5%
Busing, capacitor	350 (approx)	Changed to improve operational margin at 24 volts dc
Motor, B1	600	Changed to improve operational margin at 24 volts dc Interchangeable with older models If AIQ1 through AIQ3 are changed
CR2	600	Added zener diode 1N3036B to prevent instability under high-power conditions. (Labeled CR3 in 437S-1B only.)
A1CR27	600	Deleted.
A1R34 through A1R36	600	Changed to 820 ohm
A1R37 through A1R39	600	Changed to 560 ohm
A1R43	600	Value may vary from 120 ohm, 1 watt to 220 ohm, 1/2 watt with 150 ohm, 1 watt being nominal Choice of value is made to obtain acceptable vswr and turning stability If resistance is increased vswr improved, but instability may result AIR43 replacements should be same value as original unless specific problems have occurred.
A1R34 through A1R36	657	Changed to 27K, 1/8 watt, 10%
A1R37 through A1R39	657	Changed to 16K, 3 watt, 5%
A1CR1	775	Changed to 1N4383
C2	1200	Added 0.1 microfarad 25 wvdc capacitor from FLI-2 to FL5-2
Fine tune ferrite cores	1200	Changed fine tune ferrite cores support method
RF on circuit	1650	Changed RF on circuit coupling method
Motor, B1	1700	Added inertial damping device to motor
A1, pointed circuit board	1740	Added A1CR29 and circuit from A1A3-12 to A1A4-2, and deleted circuit from A1A3-12 to A1A4-14 Required addition of R2 when retrofitting units prior to MCN 1740
A1Q13	1900	Changed to 2N956
A2R4	1900	Changed to 1K, 1/4 watt
A1R24	2155	Changed to 1.5 megohm, 1/4 watt.
A1R5 and AIR6	2752	Changed to 54 9K, 1/8 watt, 1.0%
Fine tune ferrite cores	2865	Changed fine-tune ferrite cores support method
R2	2956	Added 3 9 megohm, 1/4 watt resistor
A1R24	2956	Changed to 820K, 1/4 watt
A1R28	2956	Changed to 1.5 megohm, 1/4 watt
C1	3200	Changed to Collins part no 922-0588-010, (higher reliability, longer life unit)
A2C1 ad A1A1C11	437S-1B, REV AD 437S-1C, REV H	Changed A2C1 from 6 pF to 4 pF  Added A1A1C11

## CHAPTER 2

## FUNCTIONING OF EQUIPMENT

## Section I. BLOCK DIAGRAM ANALYSIS

**2-1. Purpose and Use**

a. The purpose and operation of the various circuits in the antenna are explained in this chapter. The intercommunication, operation, and maintenance of equipment used with the antenna are covered in applicable system manuals. Familiarity with antenna functioning, together with a knowledge of system interconnections, will enable rapid and effective troubleshooting of the antenna, individually, or as part of a system. b The functional descriptions in paragraphs 2-2 through 2-16 are limited to the antenna. Discussions of associated equipment are included in separate system and equipment manuals (app A)

**2-2. General**

Paragraph 2-3 is a block diagram description of the antenna. A schematic diagram analysis of the antenna is furnished in paragraphs 2-4 through 2-16. The antenna is a blade type for transmission of FM signals in the vhf band. Tuning of the antenna is automatically initiated when an external transmitter connected to the antenna is keyed. During tuning time, a 3- to 5-volt square wave tuning indication is supplied by the antenna for use with an external tune indicator A remote manual tuning control is provided for tuning the antenna during radio silence conditions.

**2-3. Block Diagram Analysis (fig. 2-1)**

a. *Phase Discriminator.* Operation of the antenna coupling circuit is initiated with the application of transmitted radio frequency (rf) power in excess of 1 watt. If the transmitted frequency is below the resonant frequency of the antenna, the signal polarity developed by the phase discriminator causes the servo system to drive the series variable capacitor toward increased capacitance. If the transmitted signal is above the resonant frequency of the antenna, an error signal of opposite polarity is developed and the capacitor is driven to reduce capacitance. When a matched condition is

achieved, the discriminator output is zero and adjustment of the series capacitor ceases.

b. *Operational Amplifier* The operational amplifier amplifies the polarized Input signal from the phase discriminator and provides a polarized output signal to the servo rotation logic circuit and to the fine tune circuit.

c. *Servo Rotation Logic.* The servo rotation logic circuit detects the polarization of the input signal from the operational amplifier and establishes the direction of the rotation of the servo motor. The circuit provides an output signal to the servo motor sequencing logic circuit for direction of rotation or holding of the servo motor. The holding signal is produced when an RF-on voltage is received from the RF-on circuit. The servo rotation logic circuit also provides a signal to the sequential pulsing logic circuit when the direction of motor rotation is established.

d. *Fine Tune Circuit.* The fine tune circuit provides a small variable series inductance for incremental tuning of the antenna between steps in the variable series capacitor. The output of the circuit is controlled by the input signal from the operational amplifier.

e. *Sequential Pulsing Logic.* The sequential pulsing logic circuit is controlled by the input from the servo rotation logic circuit It provides a gating signal to the operational amplifier, a counting signal to the servo motor sequencing logic, and a tuning indication signal for use by an external tuning indicator

f. *Servo Motor Sequencing Logic.* The servo motor sequencing logic receives an input signal from the servo rotation logic and a pulse from the sequential pulsing logic. It provides sequentially controlled output signal to the servo motor control circuit. It also provides a signal to hold the servo motor in its last pulsed position when rotation signals are not applied



*g. Servo Motor Control Circuit.* The servo motor control circuit receives inputs from the servo motor sequencing logic and provides a ground for the +28-volt dc power source used to drive the servo motor.

*h. Servo Motor.* The servo motor turns in 15-degree steps and adjusts the series variable capacitor to tune the antenna circuit to resonance near the transmitted frequency.

*i. Antenna Circuit.* The antenna circuit is tuned to resonance by the series variable capacitor and by a small series variable inductance provided by the fine tune circuit.

*j. Transmit/Receive Logic.* The transmit/receive logic (RF-on) circuit inhibits the servo rotation logic against tuning to erroneous signals. The RF on circuit enables the tuning circuits when transmitter

power is applied to the antenna.

*k. Manual Override Logic.* The manual override logic is provided to enable tuning of the antenna without applying transmitted RF power.

*l. Homing Logic.* The homing logic provides a signal to return the series variable capacitor to minimum capacitance after it has reached maximum capacitance.

*m. Tuning Indicator Drive.* The tuning indicator drive circuit receives an input signal from the sequential pulsing logic and amplifies it to a 3- to 5-volt square-wave output for use in an external tuning indicator.

*n. Voltage Divider.* The voltage divider circuit converts the +28-volt dc input to proper input voltages for the circuits of the antenna.

## Section II. SCHEMATIC DIAGRAM ANALYSIS

In the detailed theory of operation discussion, the term logic "1" means a positive potential (approximately +3.5 volts dc) and the term logic "0" means a near ground potential (approximately +0.2-volt dc). Refer to the schematic diagrams, figures 5-6, 5-7, for overall circuit discussion and to figures 2-2 through 2-9 for simplified diagrams of the individual circuits.

### 2-4. Phase Discriminator Analysis

(figs. 2-2, 2-3)

The phase discriminator develops a dc error signal that is proportional to the phase shift between the RF line current.

*a.* The impedance presented to the RF signal by the antenna is either resistive, capacitive, or inductive, depending on the signal frequency and its relation to the resonant frequency of the antenna. When the RF signal frequency is below the resonant frequency of the antenna, the impedance is capacitive. Line current ( $i_L$ ) leads line voltage ( $e_L$ ) and the error signal developed is positive. When the RF signal frequency is above the resonant frequency of the antenna the impedance is inductive. Line current ( $i_L$ ) lags line voltage ( $e_L$ ) and the error signal developed is negative. When the RF signal frequency is the same as the resonant frequency of the antenna the impedance is resistive. Line current ( $i_L$ ) is in phase with line voltage ( $e_L$ ) and there is no error signal developed.

*b.* The phase discriminator is divided into two circuits. Circuit number 1 consists of points B, C, E, and F. Circuit number 2 consists of points A, D, E, and F. The line voltage ( $e_L$ ) is sampled, with no phase shift, through the capacitance between the windings of coil L3 and the transmission line. The voltage induced in L3 is 90 degrees out-of-phase with line current ( $i_L$ ). The vector

addition of the induced voltage ( $e_2$ ) and the sampled voltage ( $e_6$ ) in circuit number 1 creates a resultant voltage ( $e_4$ ). The vector addition of the induced voltage ( $e_6$ ) and the sampled voltage ( $e_6$ ) in circuit number 2 creates a resultant voltage ( $e_4$ ). The algebraic sum of the two resultants, ( $e_4$  and  $e_5$ ), is the error signal output. When the impedance is restrictive, the magnitude of the resultant voltage ( $e_4$ ) is equal to the resultant voltage ( $e_5$ ). The voltages are of opposite polarity and cancel each other so the error signal is zero. When the impedance is capacitive, the resultant voltage ( $e_4$ ) decreases in magnitude while the resultant voltage ( $e_5$ ) increases in magnitude. The algebraic sum of ( $e_4$ ) and ( $e_5$ ) causes a positive error signal output. When the impedance is inductive, the resultant voltage ( $e_4$ ) increases in magnitude while the resultant voltage ( $e_5$ ) decreases in magnitude. The algebraic sum of ( $e_4$ ) and ( $e_5$ ) causes a negative error signal output.

*c.* Resultant voltage ( $e_4$ ) is rectified by diode CR1 and filtered by FL1. Resultant voltage ( $e_5$ ) is rectified by diode CR2 and filtered by FL5. The rectification and algebraic sums of the resultant voltages create a dc error signal output proportional to the phase shift between RF voltage and RF current.

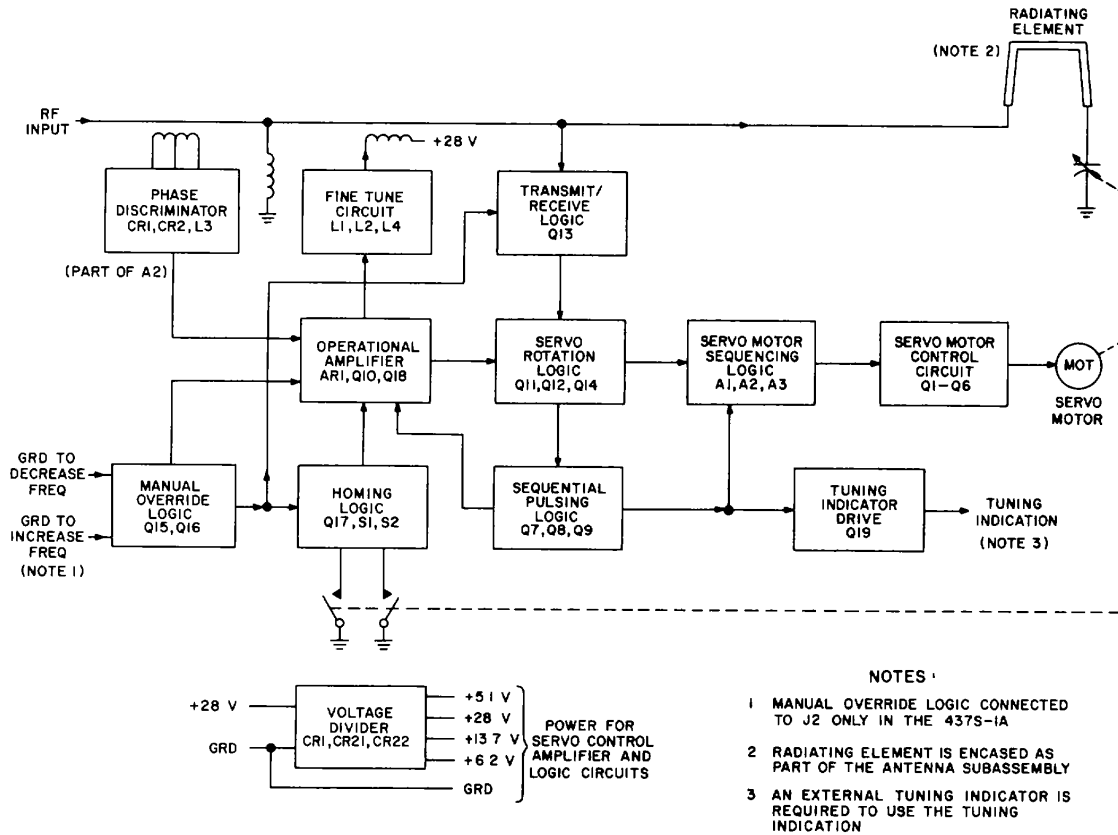

Figure 2-1. Antenna AS-285/ARC, vhf/fm blade type, functional block diagram analysis.

**2-5. Operational Amplifier Analysis**

(fig. 2-4)

Operational amplifier AR1 amplifies input signals from the phase discriminator, homing logic circuit, and manual override circuit; provides a voltage level for driving servo logic circuits; provides a voltage output for fine tuning the antenna; and contains a gating circuit to control the speed of the servo motor proportional to the operational amplifier input up to a maximum servo motor speed of 1250 rpm. The operational amplifier circuit operates as a linear voltage input to output pulse rate converter. Operational amplifier AR1 is a high-gain differential dc amplifier. With an input applied between AR1-3 and AR1-2, the amplifier produces a voltage gain of approximately 1000 with output polarity inverse of the input polarity. By means of a degenerative feedback loop consisting of (C4 and R22) and input resistor R9 the output of AR1 is controlled to a linear rate of increase. The high gain of AR1 and the control by C4, R22, and R9 produces a very sensitive amplifier, capable of sensing very low-level input signals.

b. When the output from AR1 changes above or below the threshold of CR9 or CR10, (fig. 2-5), servo rotation logic is turned on, engaging the sequential pulsing logic which, in turn, provides a gating pulse to Q18.

c. When field-effect transistor Q18 is gated, it supplies a portion of the dc voltage output as a dc voltage feedback to the input of AR1 causing the output to be pulsed in the direction of the in-put reference voltage (+6.2 volts dc). When Q18 is gated on, the amplifier circuit is limited to a gain of approximately six which is the ratio of R22 to R9.

d. With a gating pulse supplied, Q18 is a short circuit across C4 and the output voltage level is reduced (upward or downward) toward the +6.2-volt dc reference level. The output is returned to a voltage level six times the input signal level and,

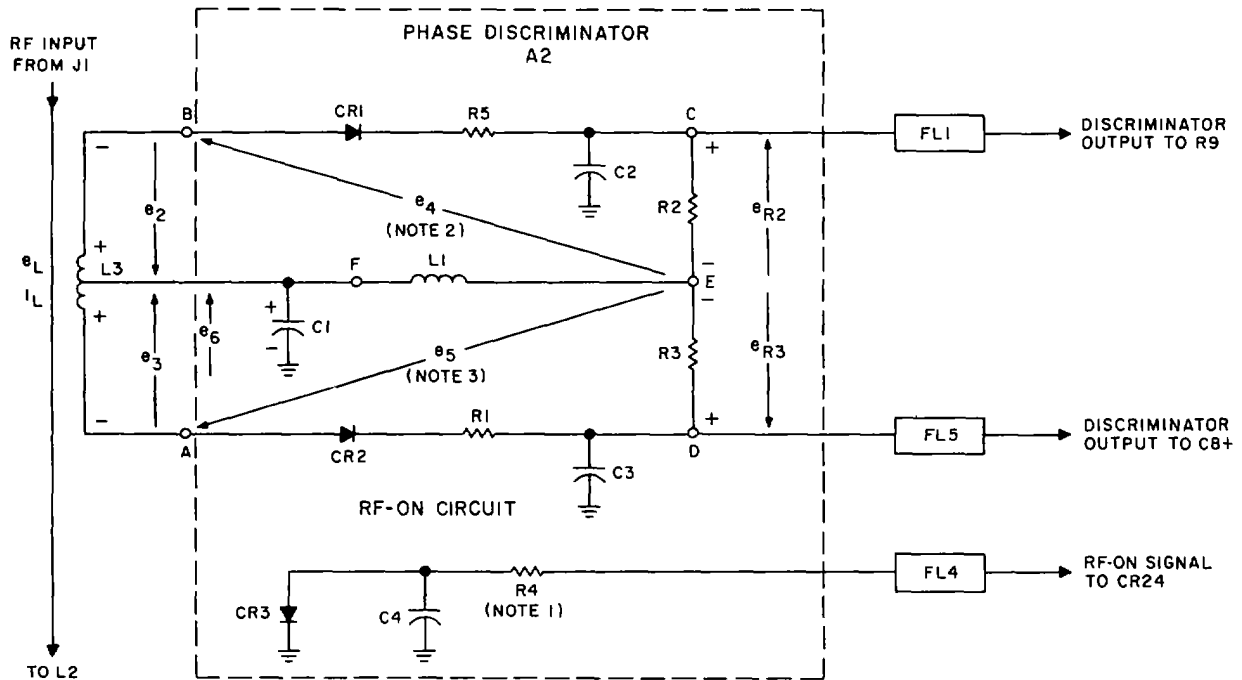

- NOTES
- 1 USED ON 437S-1/1A ONLY
  - 2  $\vec{e}_4 = \vec{e}_6 + \vec{e}_2$
  - 3  $\vec{e}_5 = \vec{e}_6 + \vec{e}_3$

ELIJP008

Figure 2-2. Phase discriminator, simplified schematic diagram.

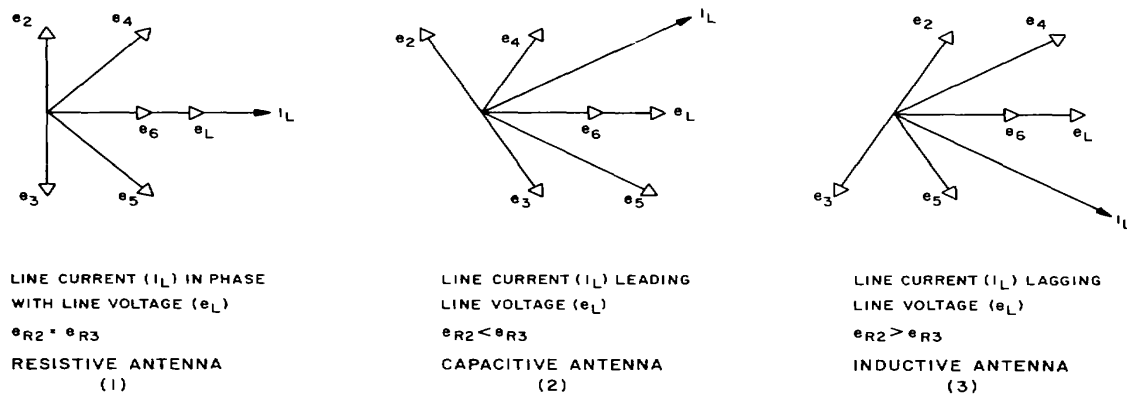

ELIJP009

Figure 2-3. Phase discriminator, vector analysis diagram.

if the output voltage is reduced to between +3.9 and +8.2 volts dc, it turns off the rotation logic, disengages the sequential pulsing logic, and removes the gating pulse from the operational amplifier. When the operational amplifier is returned between the thresholds of CR10 and CR9 by a gating pulse, the pulse rate of the gating

pulses and sequence timing pulses is determined by the time taken to again pass the thresholds of CR10 and CR9. If, when the gating pulse is supplied, the output voltage of AR1 remains below +3.9 volts dc or above +8.2 volts dc (below or

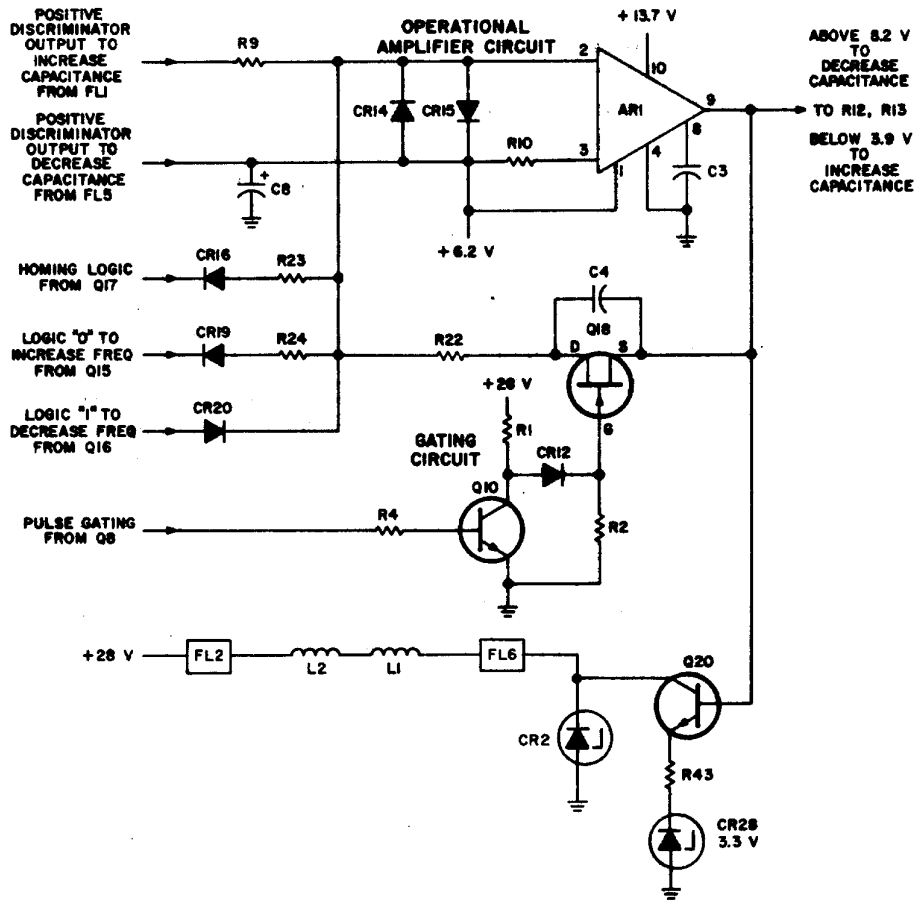

Figure 2-4. Operational amplifier, simplified schematic diagram.

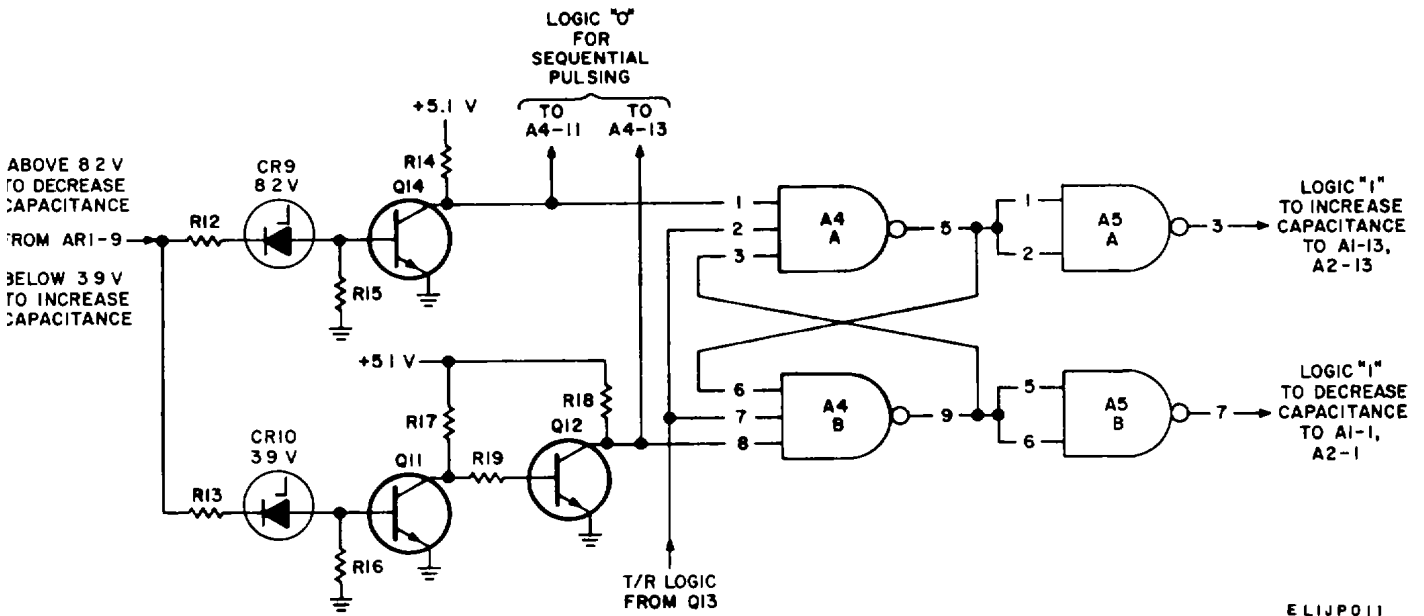

Figure 2-5. Servo rotation logic, simplified schematic diagram.

ELIJP011

above the threshold of CR10 or CR9), the rotation logic remains on and the sequential pulsing logic remains engaged. When this occurs, the sequential pulsing logic free runs providing gating pulses and sequence timing pulses at a rate of 500 Hz.

## 2-6. Servo Rotation Logic Circuits Analysis

(fig. 2-5)

The servo rotation logic provides a signal to start the sequential pulsing logic circuit, is enabled/inhibited by the RF on circuit, detects the polarization of signals from the operational amplifier AR1, and provides a signal to the servo motor sequencing logic that determines the direction of rotation of the servo motor when tuning is required and also provides a hold signal when RF power is not applied.

a. With RF transmit power applied to the antenna, a logic "1" is supplied by the RF-on circuit to enable NAND gates A4A and A4B. If tuning is required, a signal of less than +3.9 volts dc or greater than +8.2 volts dc is supplied by the operational amplifier to the input of the servo rotation logic.

b. When the output of AR1 decreases to below +3.9 volts dc, CR10 biases off, Q11 biases off, and Q12 conducts to supply a logic "0" to A4B-8. With CR10 biased off, CR9 will also be biased off and Q14 biases off to supply a logic "1" to A4A-1. With a logic "0" at A4B-8, A4B has a logic "1" output and A5B has a logic "0" output. With a logic "1" at A4A-1, a logic "1" at A4A-2, and a logic "1" at A4A-3 (supplied by A4B), A4A has a logic "0" output, and A5A has a logic "1" output. The counter-clockwise (ccw) rotation of the servo motor is initiated to increase antenna capacitance.

c. When the output of AR1 increases to above +8.2 volts dc, CR9 conducts, Q14 conducts, and a logic "0" is supplied to A4A-1. With CR9 conducting, CR10 will also conduct, Q11 conducts, and Q12 biases off to supply a logic "1" to A4B-8. With a logic "0" at A4A-1, A4A has a logic "1" output and A5A has a logic "0" output. With a logic "1" at A4B-8, a logic "1" at A4B-7, and a logic "1" at A4B-6 (supplied by A4A), A4B has a logic "0" output, and A5B has a logic "1" out-put. The clockwise (cw) rotation of the servo motor is initiated to decrease antenna capacitance.

d. When either cw or ccw rotation is initiated, a logic "0" is supplied to the sequential pulsing logic circuit.

## 2-7. Sequential Pulsing Logic Analysis (fig. 2-6)

The sequential pulsing logic circuit provides a square-wave output to step the 3-state ring counter used for motor sequencing, provides a gating pulse to the operational amplifier, and provides an external indication. When the output of the operational amplifier is above the threshold of CR9 or below the threshold of CR10, a logic "0" is supplied to NAND gate A4C on pin 11 or 13. With a logic "0" input, A4C provides a logic "1" to pin 13 of A3D. Inverter A3D supplies a logic "0" to Q7 base, biasing Q7 off. With Q7 biased off, a positive potential is applied to permit the free-running multivibrator Q8 and Q9 to supply 500-Hz square-wave output pulses to the three circuits mentioned above. However, if the gating pulse to the operational amplifier places its out-put between the thresholds of CR9 and CR10, the sequential pulsing logic will be held in its "off" state until the voltage at the operational amplifier output again passes the threshold of either CR9 or CR10. This provides a control in the out-put frequency of the free-running multivibrator to control the speed of the servo motor.

## 2-8. Servo Motor Sequencing Logic Analysis

(fig. 2-7)

The servo motor sequencing logic is a 3-state ring counter with three NAND gate outputs to provide the signals required for energizing the tuning motor.

a. Flip-flops A1 and A2 are JKLM flip-flops.

When the 1 to 0 transition of a pulse applied at the C (clock) terminal occurs, the output state of the flip-flops will change except as follows: When a logic "0" is supplied on a J and an L terminal, the flip-flop is inhibited from being set, and when a logic "0" is supplied on a K and an M terminal, the flip-flop is inhibited from being reset. When a logic "0" is supplied by A5A-3 and A5B-7, the servo motor sequencing logic will, provide a hold signal, and A1 and A2 will not change states. A1 and A2 will be locked in the state they were in when the last pulse was received. b When a logic "0" is supplied by A5A-3 and a , logic "1" is supplied by A5B-7, a clockwise rotation of the servo motor is initiated and the servo motor will rotate 15 degrees with each sequence timing pulse received. The faster the sequence timing pulses are received, the faster the servo motor will rotate. Refer to d and f (below) For the servo motor sequencing logic truth tables for clockwise rotation.

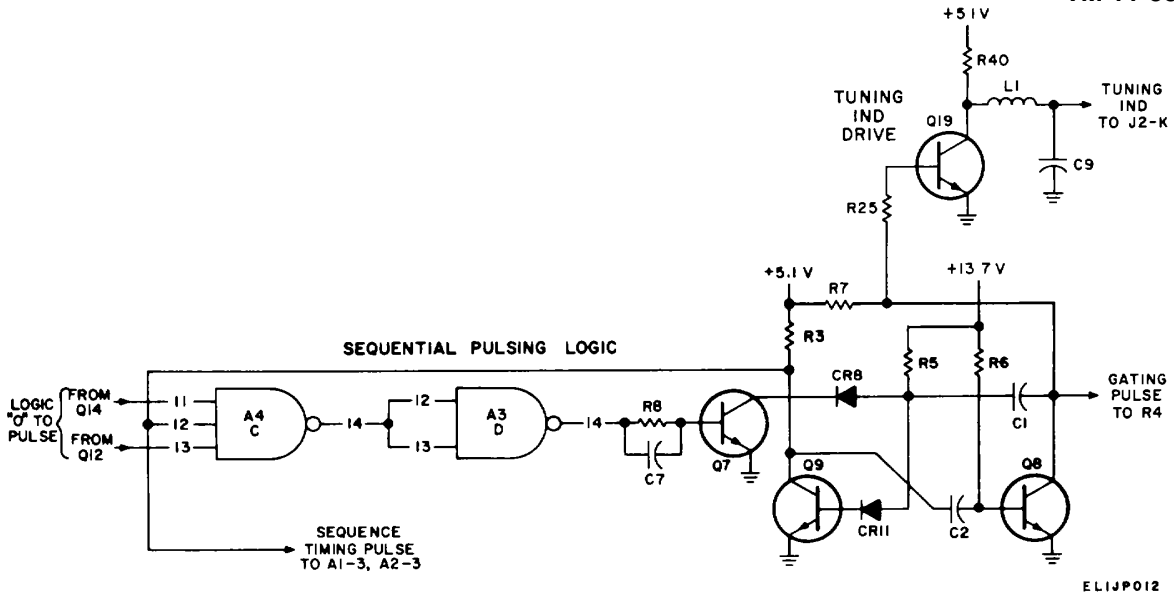

ELIJP012

Figure 2-6. Sequential pulsing logic, simplified schematic diagram.

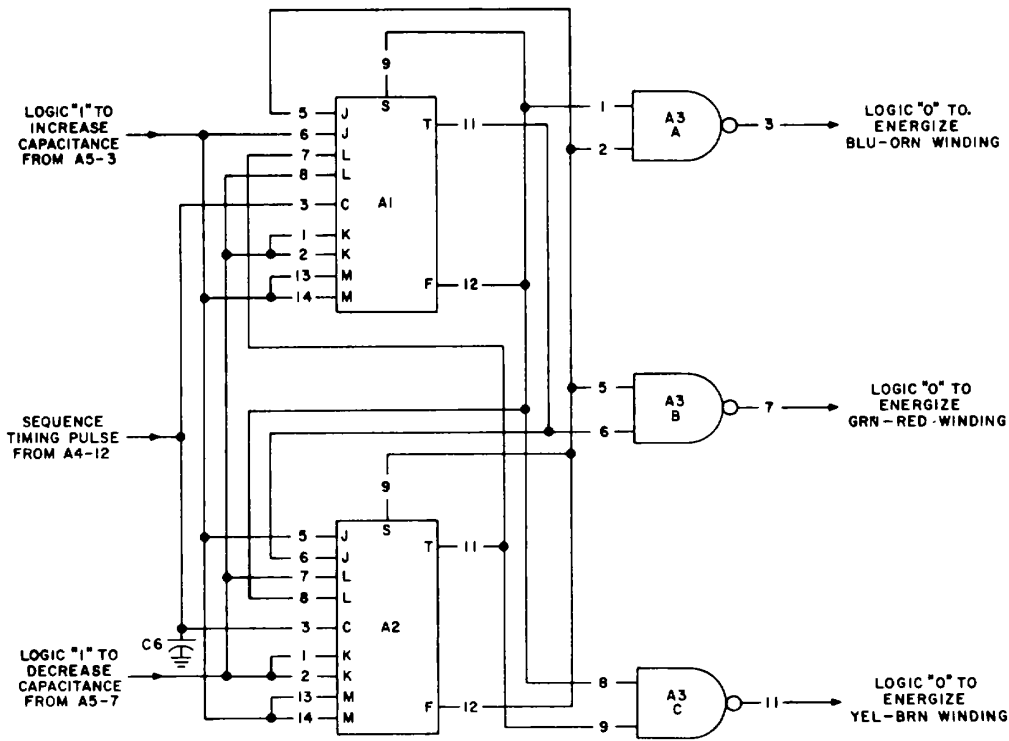

ELIJP013

Figure 2-7. Servo motor sequencing logic, simplified schematic diagram.

c. When a logic "0" is supplied by A5B-7 and a logic "1" is supplied by A5A3, a counterclockwise rotation of the servo motor is initiated. Refer to e and f (below) for the servo motor sequencing logic truth tables for counter clockwise rotation.

d. Servo Motor Sequencing Logic, Truth Table for Cw Rotation (Decrease Capacitance).

Count	Inputs						Set				Outputs	
	*OCW COMMON	**CW COMMON	J A1-5	J A2-6	L A1-7	L A2-8	S A1-9	S A2-9	T A1-11	T A2-11	F A1-12	F A2-12
A1-3, A2-3	1	0	1	0	0	n	1	1	0	0	1	1
Last previous positive pulse	1	0	0	0	1	1	1	0	0	1	1	0
First positive pulse	1	0	1	1	0	0	0	1	1	0	0	1
Second positive pulse	1	0	1	0	0	1	1	1	0	0	1	1
Third positive pulse	1	0	0	0	1	1	0	0	1	1	0	0
Fourth positive pulse	1	0	0	0	1	1	1	0	0	1	1	0

\*The following leads are ccw common: A1-1, 2, 8, and A2-1, 2, 7

\*\*The following leads are cw common: A1-6, 13, 14 and A2-5, 13, 14.

Count	Inputs						Set				Outputs	
	*OCW COMMON	**CW COMMON	J A1-5	J A2-6	L A1-7	L A2-8	S A1-9	S A2-9	T A1-11	T A2-11	F A1-12	F A2-12
A1-3, A2-3	0	1	1	0	0	1	1	1	0	0	1	1
Last previous positive pulse	0	1	1	1	0	0	0	1	1	0	0	1
First positive pulse	0	1	0	0	1	1	1	0	0	1	1	0
Second positive pulse	0	1	1	0	0	1	1	1	0	0	1	1
Third positive pulse	0	1	1	1	0	0	0	1	1	0	0	1
Fourth positive pulse	0	1	1	1	0	0	0	1	1	0	0	1

Note 1: \*The following leads are ccw common: A1-1, 2, 8 and A2-1, 2, 7

Note 2: \*\*The following leads are cw common: A1-6, 13, 14.

Inputs						Outputs			Results
A3A	A3B		A3C			A3A	A3B	A3C	
1	2	5	6	8	9	3	7	11	
1	1	(1)	0	(1)	0	0	1	1	Energizes blu-orn winding
0	(1)	1	1	(0)	0	1	0	1	Energizes gm-red winding
(1)	0	(0)	0	1	1	1	1	0	Energizes yel-brn winding

Note 1: Logic numbers in parenthesis are not required but are present because of other required Inputs.

Note 2: For cw rotation the windings are energized in the following sequence Blu-orn, yel-brn. and grn-red

Note 3: For cow rotation the windings are energized in the following sequence Blu-orn, gmrn-red, and yel-brn

## 2-9. Servo Motor and Motor Control Logic Analysis

(fig. 2-8)

The servo motor control logic consists of 3 basic electronic switches. With a logic "1" input to Q6, transistor Q6 conducts to supply a logic "0" at the base of Q3. Transistor Q3 biases off. A +28-volt dc signal is supplied through CR4 to the blue-orange winding of the dc stepper servo motor for protection of Q3 from spikes generated by motor windings.

a. With a logic "0" input of Q6, transistor Q6 biases off supplying a logic "1" to the base of Q3. Transistor Q3 conducts to supply a ground potential to energize the blue-orange winding of the dc stepper motor.

b. The discussions concerning Q6, Q3, CR4 and the blue-orange winding of the de stepper motor is also true about Q5, Q2, CR3 and the green-red winding, and Q4, Q1, CR2 and the yellow-brown winding.

c. For a clockwise rotation of the dc stepper motor the windings are energized in the following sequence: blue-orange, yellow-brown, and green-red.

For a counterclockwise rotation of the dc stepper motor the windings are energized in the following sequence: blue-orange, green-red, and yellow-brown. The dc stepper motor is a variable reluctance step' servo motor and will step 15 degrees each time a different winding is pulsed. The faster the motor is pulsed, the faster it rotates. The dc stepper motor is mechanically linked to variable capacitor C1.

## 2-10. Fine Tune Circuit Analysis

(fig. 2-4)

The fine tune circuit produces a small variable series inductance to provide incremental tuning of the antenna.

a. With an output from the operational amplifier AR1, conduction through Q20 changes, providing a change in current in L1 and L2. Coils L1 and L2 produce a change in magnetic field proportional to operational amplifier input voltage. The change in magnetic field generated by L1 and L2 changes the permeability of the ferrite

core near plug P1. The antenna passes through this core and, with the permeability of the core being changed, the core acts as a small variable series inductance to the antenna.

b. This small variable series inductance tunes the antenna between the variable capacitor C1 capacitance values provided by the motor steps.

## 2-11. Transmit/Receive Circuit Analysis

(figs. 2-2, 2-9)

The transmit/receive circuit detects when RF power is supplied to the antenna and uses this signal to enable the tuning circuits.

a. When the transmitter that is connected to the antenna RF input is keyed, the RF-on circuit detects the keyed RF power through CR3, providing a negative voltage at the base of Q13. Transistor Q13 biases off supplying a logic "1" to A4A-2 and A4B-7. This enables the tuning logic of the antenna coupler.

b. When the transmitter that is connected to the RF input is not keyed, CR3 biases off. With CR3 biased off a positive potential is supplied to the base of Q13. Transistor Q13 conducts to supply a logic "O" to A4A-2 and A4B-7, providing a lock-on voltage for the servo motor.

## 2-12. Homing Logic Analysis

(fig. 2-9)

The homing logic supplies a homing signal to re-turn the antenna tuning capacitor to minimum after it has reached maximum capacitance.

a. The homing logic is controlled by the limits of variable capacitor C1. When capacitor C1 reaches maximum capacitance, limit switch S2 closes to supply a logic "O" to A5C-8. NAND gate A5C supplies a logic "1" from A5C-11 to the base of transistor Q17 and A5D-12. NAND gate A5D has a logic "1" input on pin 13 while limit switch S1 is open. NAND gate A5D with both logic "1" inputs supplies a logic "O" to A5C-9. This logic "O" is also supplied through CR29 to the base of Q13 (units MCN 1740 and above). Transistor Q13 is biased off and a logic "1" is supplied from the collector of Q13 to enable the tuning logic circuits. Upon initial application of power, the antenna tuning capacitor is driven to minimum capacity (units MCN 1740 and above). The above conditions remain until C1 reaches its minimum capacitance where S1 closes and supplies a logic "O" to A5D-13. NAND gate A5D supplies a logic "1" to A5C-9; a logic "1" is also supplied to A5C-8 because limit switch S2 is open. Therefore, NAND gate A5C with both logic "1" inputs supplies a logic "O" input to the base of Q17 and A5D-12.

b. With a logic "1" on the base of Q17,

transistor Q17 conducts to supply a near ground potential to diode CR16 to drive the servo motor toward minimum capacity. With a logic "O" on the base of Q17, transistor Q17 biases off and permits the antenna coupler to seek a null.

## 2-13. Manual Override Logic Analysis

(fig. 2-9)

The manual override logic provides a means of tuning the antenna without applying transmitted power.

a. Under normal conditions, a logic "1" input is supplied to A6B-5, A6B, A6C-8, A6C-9, and the base of transistor Q16. With a logic "1" on both inputs of NAND gate A6B, a logic "O" is supplied to NAND gate A6A. A6A, used as an inverter, supplies a logic "1" to diodes CR18 and CR23, permitting the normal homing logic and transmit/receive signals to be passed. A logic "1" on the inputs of NAND gate A6C, used as an inverter, supplies a logic "O" to the base of transistor Q15. Transistor Q15 is biased off, supplying a logic "O" to the base of transistor Q15. Transistor Q15 is biased off, supplying a logic "1" to diode CR19, disabling the manual override logic increase frequency signal. A logic "1" on the base of transistor Q16, causes Q16 to conduct and supply a logic "O" to diode CR20, disabling the manual override logic decrease frequency signal.

b. With a ground supplied to decrease frequency, a logic "O" is supplied to the base of Q16 and A6B-5. NAND gate A6B supplies a logic "1" to A6A. NAND gate A6A supplies a logic "O" through CR18 and CR23 to the base of Q17 and base of Q13. Transistor Q17 biases off, supplying the normal tuning signal to CR16. Transistor Q13 biases off, supplying A4A-2 and A4B-7 with a logic "1" RF-on signal, enabling the tuning logic. With a logic "O" input at transistor Q16, Q16 biases off and supplies a logic "1" to CR20, causing the coupler to tune toward maximum capacitance of the antenna tuning capacitor thereby reducing the resonant frequency of the antenna.

c. With a ground supplied to increase frequency, diode CR26 conducts supplying a logic "O" to A6C-8, 9 and A6B-6 NAND gate A6B supplies a logic "1" to A6A. NAND gate A6A supplies a logic "O" through CR18 and CR23 to the base of Q17 and the base of Q13. Transistor Q17 biases off, supplying the normal tuning signal to CR16. Transistor Q13 biases off, supplying A4A-2 and A4B-7 with a logic "1" RF-on signal, enabling the tuning logic. NAND gate A6C with logic "O" inputs supplies a logic "1" output to the



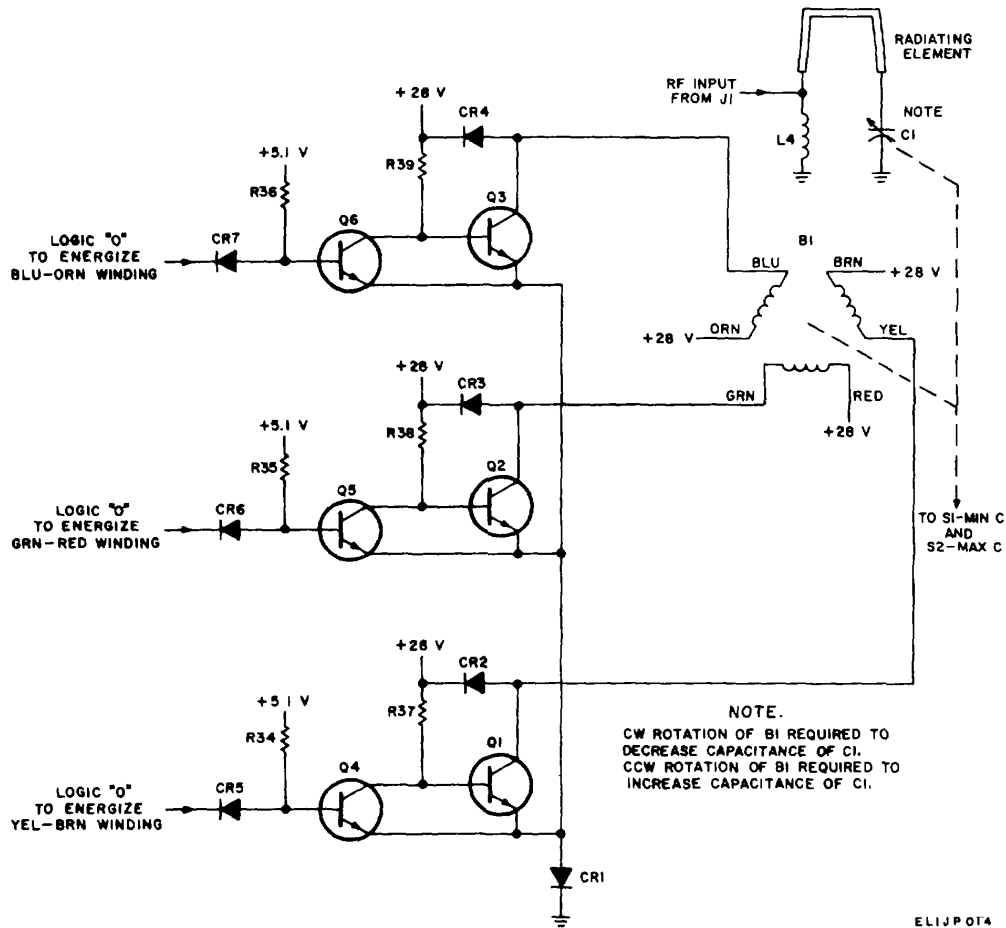

Figure 2-8. Servo motor and motor control logic, simplified schematic diagram.

base of Q15. Transistor Q15 conducts supplying a logic "O" to CR19 and causing the coupler to tune toward minimum capacitance of the antenna tuning capacitor thereby increasing the resonant frequency of the antenna.

**2-14. Antenna Circuit Analysis (FO 6-2, 6-3)**

The antenna is a vertically polarized, folded monopole, matched to the impedance of a 50-ohm transmission line.

a. The antenna circuit is tuned by varying series capacitance. Shunt inductor L4 matches the antenna impedance with the impedance of a 50-ohm transmission line when the antenna circuit is at resonance.

b. A small ferrite core placed around the antenna uses the magnetic field generated by L1 and L2 to change permeability. The change in permeability of

the ferrite core produces a small variable series inductance used for fine tuning the antenna.

**2-15. Power Sources Analysis**

(Fo 6-2, 6-3)

The power required by the antenna is a +28-volt dc source This +28-volt dc source controls three voltage dividers for the operation of the antenna. A +5.1-volt dc divider is used for logic functions, a +6.2-volt dc divider is used for a signal reference in the operational amplifier ARI, and a + 13.7-volt dc divider is used for gating functions.

**2-16. Tuning Indicator Drive Analysis**

(fig. 2-6)

The tuning indicator drive supplies square-wave output pulses (nearly identical to pulses supplied

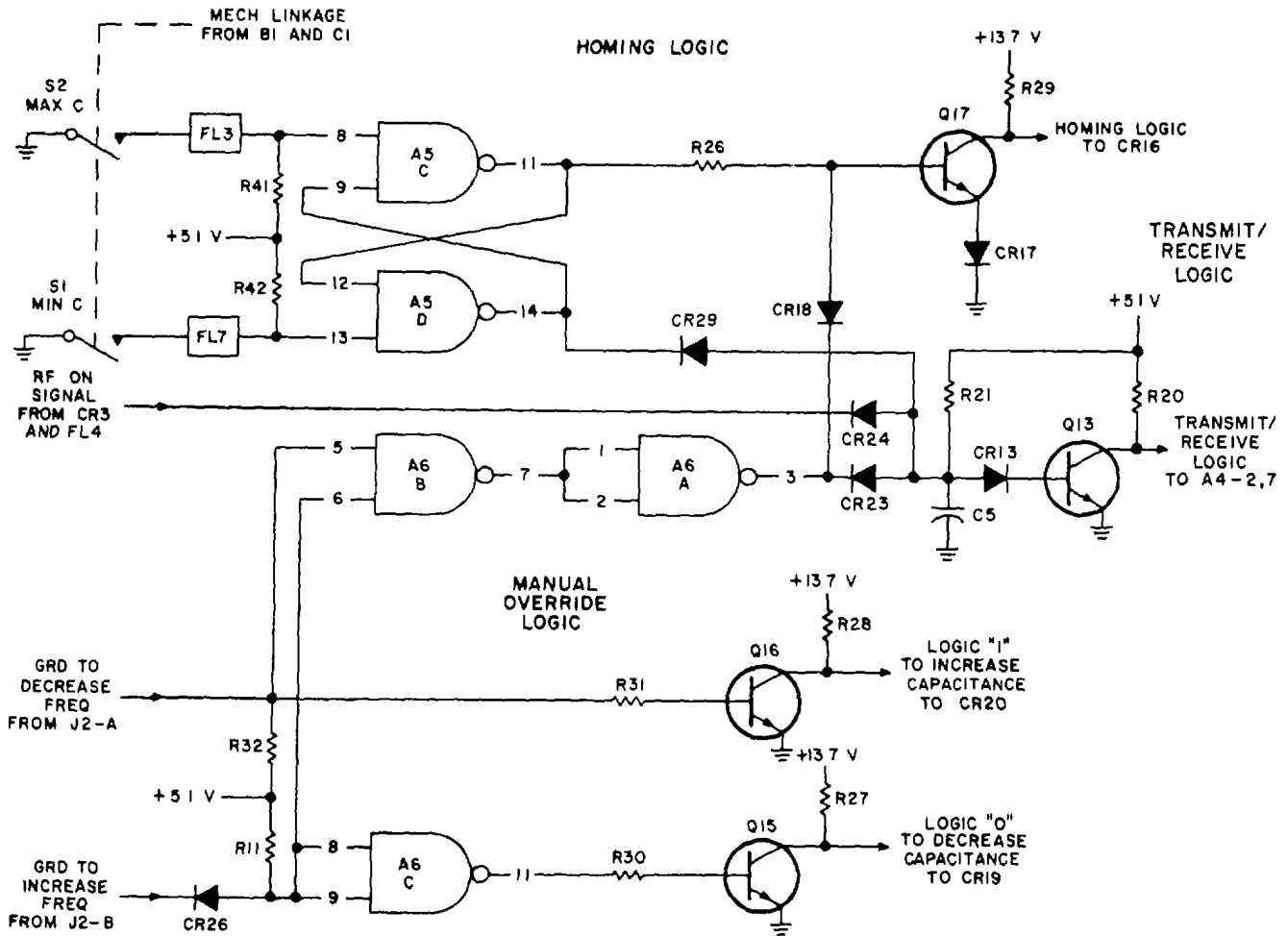

ELIJP015

Figure 2-9. Transmit/receive logic, homing logic, and manual override logic, simplified schematic diagram.

by Q10 for gating the operational amplifier) for use by a remote tuning indicator, Pulses from the output of multivibrator Q8 and Q9 are supplied to Q19. Transistor

Q19 amplifies these pulses and supplies them through radio frequency integrator L1 and C9 to an external tuning indicator.

CHAPTER 3

DIRECT SUPPORT MAINTENANCE

Section I. GENERAL

**3-1. Scope of Direct Support Maintenance**

a. This chapter provides instructions and essential illustrations covering testing and troubleshooting of the antenna. Maintenance of the antenna at the direct support category is limited to replacement of the radome or coupler assembly.

b. Troubleshooting at the direct support category supplements and includes the techniques outlined for organizational maintenance (TM 11-5821-284-20) and all other techniques that may be required to isolate a defective part. The systematic troubleshooting procedures, which begin with the operational checks at an organizational category, are supplemented and extended by localizing and isolating techniques at the directed support category,

**3-2. Tools, Test Equipment, and Materials Required**

Tools and test equipment required for direct support maintenance are listed below:

<i>Item</i>	
Test Set, Antenna AN/ARM-115	Provides control and monitoring circuits for equipment under test.
Oscilloscope, AN/USM-281	Measures servo amplifier and sequencing circuit waveforms.
Receiver-transmitter RT-8q8/ARC-181	Provides RF source for coupler tuning.
Maintenance Kit MK-1085/ARC-131	Connects RF source to power supply and coupler.
Power supply. (capable of providing 28.0	Provides +27.5 Vdc power for circuits.
Resistor, fixed carbon (6850-ohm, or 5600-ohm, .10X7, ¼-watt resistance power rating)	Used in testing model 437S-1B antenna to decrease input of servo amplifier circuit.

Section II. DIRECT SUPPORT TROUBLESHOOTING

**3-3. Troubleshooting Procedure**

To be effective, troubleshooting must be systematic. Generally, it is necessary to perform a sequence of operational checks, observations, and measurements before a defect will be revealed. If the proper sequence is used, the trouble will be traced first to a unit, and then to a portion of the unit. The sequence of steps is commonly referred to as the sectionalization and localization of a trouble.

a. *Sectionalization.* A defect in radio set or communication system should first be sectionalized to a particular unit. This normally is accomplished through visual checks and meter readings during system operational testing.

b. *Localization.* When the defective unit in a system has been isolated to an antenna, localize the trouble to a particular portion of the antenna by inspection or by performance testing procedures.

**CAUTION**

If possible, obtain operational symptoms before applying power to an antenna. This

procedure may eliminate the possibility of further damage when power is applied.

**WARNING**

Be extremely careful when working around the antenna or the antenna terminals. RADIO FREQUENCY HIGH VOLTAGES EXIST AT THE TERMINALS. Operator and maintenance personnel should be familiar with the requirements of TB SIG 291 before attempting installation or operation of the

equipment covered in this manual. Failure to follow requirements of TB SIG 291 could result in injury or DEATH.

**3-4. General Precautions**

a. When testing or troubleshooting the antenna, make sure that the power supply voltage is correct. Abnormal supply voltages often affect frequency and stability characteristics and the output or gain of the circuits.

b. Do not come in contact with components or wiring when power is applied to the antenna.

**3-5. Antenna Troubleshooting**

Antenna troubleshooting consists of operational testing and signal sampling to check the overall capability of the antenna. If proper results are not obtained during these tests or if other abnormalities are observed, refer to the troubleshooting chart (d(2)) below to isolate the probable cause of the trouble.

*Figure No*

- 5-61
- 5-62
- 5-7
- 5-8
- 5-9
- 5-10
- FO 6-2
- FO 6-3
- FO 6-4

*Illustration*

- 437S-1/1A/1C coupler assembly test points (sheet 1 of 2).
- 437S-1/1A/1C coupler assembly test points (sheet 2 of 2)
- 437S-1/1A/1C coupler connector J2 test points
- Servomplifier circuit board A1 test points
- A1A1 through A1A6 flat pack test points
- Operational amplifier A1AR1 test points.
- AS-2285/ARC (Model 437S-1/1A/1C) Schematic Diagram
- AS-2285/ARC (Model 437S-1B) Schematic Diagram
- AS-2285/ARC Antenna Waveforms

d. Troubleshooting Checks.

*General.* The troubleshooting chart, (2) below, is an aid in locating troubles in the individual circuits of an antenna stage after trouble has been isolated to a specific stage or circuit of the antenna through the equipment performance check (section IV) or signal sampling tests (b), above. Refer to the schematic wiring diagrams list ©, above, for further aid in troubleshooting the antenna circuits after trouble has been isolated to specific stage.

(2) *Troubleshooting Chart.*

**NOTE**

Perform the equipment performance tests in section IV; when a test step is failed, refer to the applicable test of the troubleshooting chart.

Sentence No.	Trouble symptom	Probable cause	Corrective action
1	Antenna reflected power is more than 25% of forward power	Defect in coupler or antenna circuits	Proceed to item 2 for further isolation of trouble
2	a. Incorrect waveform at J2-K when pin 10 or pin 12 of circuit board A1 is grounded b. Correct waveform at J2-K when pin 10 or 12 of circuit board A1 is grounded but actuator arm does not operate	a. Defect in servo amplifier, pulsing, or manual override circuits b. Defect in sequencing servo control, or servo motor circuits	a. Replace coupler. b. Replace coupler

**Section III. DIRECT SUPPORT REPAIR AND REPLACEMENT**

**3-6. General**

Replacement of a radome or coupler is the only repair authorized at the direct support maintenance category. When a radome or coupler is found to be malfunctioning, replace it with a new part. Send the malfunctioning part to a general support maintenance facility for repair.

**3-7. Separation of Radome Assembly A2 and Coupler**

**assembly A1.**  
(FO 6-5)

- a. Remove fourteen (14) screws H14 from the base of the antenna.
- b. Carefully pull coupler assembly from the radome assembly. This can easily be done by grasp-

ing the mating connector attached to J2 and rocking the assembly. If a screw driver is used to loosen the coupler assembly, the gasket may be damaged.

**3-8. Reassembly of Coupler Assembly A1 and Radome Assembly A2.**

(fig. 6-5)

**NOTE**

Be sure that the coupler gasket is properly in place to insure a good

moisture seal.

a. Carefully slide the coupler into the radome. Make sure that the spring at the top of variable capacitor is not damaged.

b. Make sure that all 14 holes are aligned when the coupler and radome assemblies are together. Secure the assemblies with the fourteen (14) screws H14.

**Section IV. DIRECT SUPPORT TESTING PROCEDURES**

**3-9. General**

a. Testing Procedures. Testing procedures are prepared for use by direct support personnel to determine acceptability of repaired signal equipment. These procedures set forth requirements that repaired signal equipment must meet before it is returned to the using organization. The testing procedures may also be used as a guide for the testing of equipment during troubleshooting procedures. A summary of the performance standards is given in paragraphs 3-11 through 3-13.

b. Test Instructions. Comply with the instructions preceding the body of the chart before proceeding to the tests. Perform each test in sequence. Do not vary the sequence. For each step, perform all the actions required in the test equipment control setting column; then perform each specific test procedure and verify it against its performance standard. If an antenna is below standard on any test, refer to the troubleshooting chart in section II.

Tests must be performed in an area free of externally generated RF fields (no nearby antennas or transmitting sources). Tests must be performed outdoors, away from nearby metal structures, or in a very large room with no nearby metallic obstructions.

**NOTE**

When testing antenna model 437S-1B, replace R9 on circuit board A1 with a 5600-ohm resistor or connect a 6850-ohm resistor in parallel with A1R9. Remove resistor when testing is complete.

**3-11. Physical Tests and Inspection**

- a. Test Equipment and Materials. None.
- b. Test Connections and Conditions. None.
- c. Procedure.

**3-10. Special Requirements**

Step no.	Test equipment control settings	Test procedure	Performance standard
1	N/A	Inspect radome for cracks, chips, and breaks.	Radome should be free of cracks, chips, or breaks.
2	N/A	Inspect coupler for loose or missing screws.	Screws are tight; none missing.

**3-12. Antenna VSWR Test**

- a. Test Equipment and Material.
  - (1) Test Set, Antenna AN/ARM-115.
  - (2) Maintenance Kit MK-1035/ARC-131.
  - (3) Receiver-transmitter RT-823/ARC-131.

(4) Power Supply.

b. Test Connections and Conditions. Connect The equipment as shown in figure 3-1 with ground plane. Turn on the equipment and allow 5-minute warmup before proceeding.

Step no.	Test equipment control settings	Test procedure	Performance standard
1	AN/ARM-115: METER FUNCTION: FWD on 10-W SCALE.	Measure forward and reflected power at 30 MHz. Divide reflected power by forward power and	Reflected power is less than 25% of forward power.

Step no.	Test equipment control settings	Test procedure	Performance standard
	MV ADJUST: fully CCw. MANUAL TUNE: OFF. RT-828/ARC-181: Adjust for 8-0-MHz output, maximum power, Power Supply: Adjust for +27.5 Vdc	multiply result by 100 to determine percent of reflected power. Use the following formula: Reflected power _____ X100=reflected power	NOTE If indication is abnormal in any of the steps, in any of the steps replace the coupler
2	Same as step 1, except set RT-823/ARC-31 for 85-MHz output.	Forward power Measure forward and reflected power at 85 MHz.	Antenna tunes to 35 MHz and reflected power in less than 25% of forward power.
3	Same as step 1, except set RT-828/ARC-181 for 40-MHz output.	Measure forward and reflected power at 40 MHz.	Antenna tunes to 40 MHz and reflected power is less than 26% of forward power.
4	Same as step 1, except set RT-828/ARC-181 for 45-MHz output.	Measure forward and reflected power at 45 MHz.	Antenna tunes to 46 MHz and reflected power is less than 25% of forward power.
5	Same as step 1, except set RT-828/ARC-181 for 50-MHz output.	Measure forward and reflected power at 50 MHz,	Antenna tunes to 60 MHz and reflected power is less than 25%, of forward power.
6	Same as step 1, except set RT-828/ARC-1S1 to 65-MHz output.	Measure forward and reflected power at 65 MHz.	Antenna tunes to 55 MHz and reflected power is less than 265% of forward power.
7	Same as step 1, except set RT-828/ARC-181 to 60-MHz output.	Measure forward and reflected power at 60 MHz.	Antenna tunes to 60 MHz and reflected power is less than 265% forward power.
8	Same as step 1, except set RT828/ARC-111 to 65-MHz output.	Measure forward and reflected power at 65 MHz.	Antenna tunes to 65 MHz and reflected power is less than 26% forward power.
9	Same as step 1, except set RT-823/ARC-181 to 70-MHz output.	Measure forward and reflected power at 70 MHz.	Antenna tunes to 70 MHz and reflected power is less than 25% forward power.
10	Same as step 1, except set RT-828/ARC-181 to 75.95 MHz output.	Measure forward and reflected power at 75.95 MHz.	Antenna tunes to 75.95 MHz and reflected power is less than 26%/c forward power.

**3-13. Manual Cycle and Run Signal Test**  
 a. Test Equipment and Material.  
 (1) Test Set, Antenna AN/ARM-115.  
 (2) Oscilloscope AN/USM-281.  
 (3) Power Supply PP-1104/G or c. Procedure.

equivalent.

b. Test Connections and Conditions.

Step no.	Test equipment control settings	Test point	Test procedure	Performance standard
1	N/A	N/A	Manually cycle variable capacitor I01 from one limit to other. ment and does not drag	Variable capacitor C1 travels smoothly over entire range of move-  or have any tight spots. Capacitor travels full range before tripping limit switches S1 and S2.
2	Power Supply: ON. controls to observe AN/USM-281 : Set	TP17	a. Ground pin 10 of circuit board A1. Connect AN/USM-281 to	a. Waveform is same as that shown in figure 6-4V. T2 is 25 ±15 ms.

Step no.	Test equipment control settings	Test point	Test procedure	Performance standard
	waveforms shown in figures 6-8V and 6-8W. AN/ARM-11S METER FUNCTION: OFF. MANUAL TUNE: OFF. MV ADJUST: fully ccw.		J2-K and observe waveform.  b. Remove ground from pin 10 and ground pin 12 of circuit board A1. Observe waveform at JZ-K.  c. Remove ground from	Capacitor actuator arm moves in when switch is thrown.  b. Waveform is same as that shown in figure 6-4W. T2 is 25 t15 ms. Capacitor actuator arm moves out when switch is thrown.  c. None.

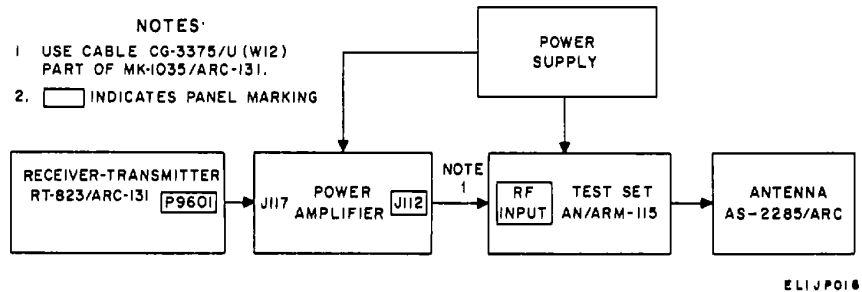

Figure 3-1. Test connections, antenna vswr test.

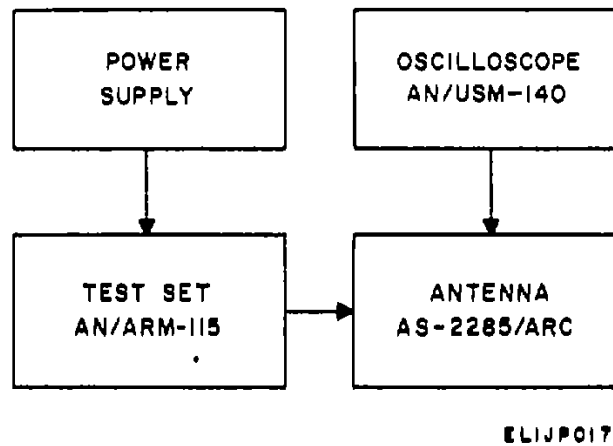

Figure 3-2. Test connections, manual cycle and run signal test.

## CHAPTER 4

### GENERAL SUPPORT MAINTENANCE

---

#### Section I. GENERAL

##### 4-1. Scope of General Support Maintenance

*a. General Support Maintenance* General support maintenance supplement direct support maintenance, and encompass all maintenance categories. The troubleshooting procedures in this chapter are prepared for use by general support maintenance shops to locate and repair a malfunctioning circuit. They are used in conjunction with the Performance Standards of chapter 5 Overhaul tasks can be effected using the normally authorized tools and test equipment.

*b. Depot Repair* Depot repair is covered In DMWR 11-5821-284.

##### 4-2. Test Equipment and Additional Equipment Required

In addition to the test equipment authorized for direct support maintenance (para 3-2), the multimeter ME-26B/U is required for measurement of ac and dc voltages and resistance.

##### 4-3. General Precautions

*a.* When servicing the antenna components observe the following precautions:

(1) Connect a suitable ground to the antenna. This is a safety precaution and also prevents abnormal electrical effects caused by the absence of a ground connection.

(2) Remove all power from the antenna and from the component under test before contacting any of the wiring or parts that are connected to, or in the vicinity of, high voltage. Also, discharge the capacitors before touching the part.

(3) Observe all proper precautions to assure safety to personnel and equipment when making high voltage and current measurements. Disconnect all power and discharge capacitors before making any resistance measurements.

(4) Make sure that all cable and card connections are correct before operating or testing components.

(5) Before testing or troubleshooting, check the source voltage of the power supply circuits. Abnormal supply voltages often affect frequency any stability characteristics and the output or gain of the circuits.

*b.* When troubleshooting transistorized circuits, observe the following:

(1) In a transistorized amplifier, any change in the output circuit of one stage can affect all preceding stages; therefore, any deviation in the operating characteristics of a certain stage can be reflected back to affect the operation of the preceding stages

(2) Common-emitter transistorized amplifiers have a 180 phase shift between the input and output voltage; however, there will be no phase shift between the input and output signals if the base is short-circuited to the collector.

(3) During normal operation of a common-emitter transistor amplifier, the base voltage should be slightly higher than the emitter voltage. An open circuit between the base and emitter will produce a base voltage considerably greater than normal and an emitter voltage near ground potential

(4) An unusually high dc collector voltage can be caused by an open emitter circuit, an open collector circuit, or a short circuit between the base and emitter. An open circuit between the base and emitter may also cause an unusually high collector voltage.

(5) An unusually low dc collector voltage indicates a short circuit between the collector and ground, the collector and emitter, or the collector and base or across the output impedance.

##### 4-4. Troubleshooting Procedures.

Troubleshoot the antenna using the chart below, and the tests in the Performance Standards, chapter 5 Perform the tests in the order given in chapter 2 and



refer to the corresponding item of the troubleshooting chart when a fault is observed. Item 1 in the troubleshooting chart corresponds to test 5-4 in the

Performance Standards, item 2 to test 5-5 etc, this relation is maintained throughout the troubleshooting chart.

**4-5. Troubleshooting Chart**

<i>Sequence No.</i>	<i>Doe Test</i>	<i>Trouble Symptom</i>	<i>Probable Cause</i>	<i>Corrective Action</i>
1	5-4	Incorrect voltage between FL1 and FL6.	Defect In phase discriminator	Check A2CR1, A2CR2, and associated components. If L3 has been replaced, adjust the turn spacing of the wires around toroidal core L3E1 to obtain 0.4 to 1.0 volt positive at FI, 1 with respect to FL5. Apply adhesive (Armstrong A12 and A12T) to cement wire to the core and core spacer MP24 (figure 6-6). Keep adhesive off antenna element MP13.
2	5-5	Incorrect waveform at J2-K when RF is applied to coupler	Defect in servo amplifier, pulsing, sequencing, servo control or servo motor circuits Defect in FL1, FL5 or A1R9.	Check FL1, FL5, and AIR9. Perform individual test of each circuit to isolate trouble.
3	5-6	Incorrect waveform at FL6 when 100 mv is applied to servo amplifier at FL1	Defect in servo amplifier, or pulsing circuits.	If results of items 2 and 4 were abnormal check servo amplifier and pulsing circuits.
4	5-7	Incorrect waveform at J2-K when 100 mv is applied to servo amplifier at FL1 and FL5	Defect In servo amplifier or pulsing circuit &	If one planarity is normal and the other is not, check AiCR14, AICR15, and associated components. If neither polarity is correct check A1AR1 and pulsing circuit.
5	5-8	Antenna does not cycle normally when F1A4 is grounded.	Defect In receive/transmit logic circuits.	Check ALQ13 and associated components.
6	5-9	a. Capacitor does not run completely out when S2 is tripped	Defect In homing circuit logic	Check S2, A1ASC, A1A5D, A1Q17, A1CR16, A1CR17, AICR18, A1A6, and associated components.
		b. Capacitor does not run completely in when S1 is tripped.	Defect in homing circuit logic.	Check S1, A1A5C, A1A5D, A1Q117, A1CR16, A1CRI7, AICR18, A1A6, and associated components.
7	5-10	a. Voltage at pin 2 of circuit board AI is above	(1) External supply voltage incorrect (2) Internal short in +27.5 Vdc line	Check external supply voltage and adjust for +27.5 Vdc. Check AiC10
		b. Voltage at pin 5 of circuit board AI is above or below +6.2 Vdc	Short or open in +6.2 Vdc line.	If voltage is high check A1CR22 and ground connections for open circuits. If voltage is low check A1CR22, A1C8, A1C3 and A1AR1, for short circuits. Check A1CR21 and A1R33 for open circuits.
		c. Voltage at AIARI-10 is above or below +13.7 Vdc.	Short or open in +13.7 Vdc line.	If voltage is high, check A1CR21 and A1CR22 for open circuits.

Sequence No.	Doe Test	Trouble Symptom	Probable Cause	Corrective Action
8	5-11	<p>d. Voltage at pin 8 of circuit board A1 is above or below +5.1 Vdc.</p> <p>Incorrect waveform at A1AR1-9 when limit switch S1 is tripped.</p>	<p>Short or open in +5.1 Vdc line.</p> <p>Defect in sequential pulsing or servo amplifier circuit. A1C9, A1L1, and A1Q19.</p>	<p>If voltage is low, check A1CR21 and A1AR1 for short circuits. If voltage is high, check A1CRP for open circuit.</p> <p>If voltage is low, check A1CR1, A1A1 thru A1A6 and associated components for short circuits. Check A1R1 for open circuit.</p> <p>a. If coupler runs and waveform is not correct check</p> <p>b. If a steady voltage between +3.9 and +8.2 Vdc is observed check AIQ18 gate voltage.</p> <p>(1) If AIQ18 gate is <sup>+28</sup> Vdc check A11Q18 and A1AR1. Check for short circuit of A1C4. If A1Q18 gate is 0 Vdc check A1R1 and A1CR12 for open circuits and R2 for short circuit.</p> <p>(2) Check A1Q8 collector voltage. If voltage is above +3.0 Vdc, check A1Q8 and A1C1 and A1C2 for short circuits. If voltage is below +0.3 Vdc check for bad A1Q10</p> <p>c. If a steady voltage above +8.2 Vdc is observed at A1AR1-9, check A1Q14 collector voltage.</p> <p>(1) If A1Q14 collector is below +0.3 Vdc proceed to item 10e.</p> <p>(2) If A1Q14 collector is above + 0.3 Vdc check A1Q14, A1CR9, A1R12 and A1R15.</p> <p>d. If a steady voltage below + 3.9 Vdc is observed at A1AR1-9 check A1Q12 collector voltage.</p> <p>(1) If A1Q12 collector is below +0.3 Vdc proceed to item 10e.</p> <p>(2) If A1Q12 collector is above + 0.3 Vdc check A1Q12, A1R19, A, Q1, A1CR10, A1R13 and -A1R16</p> <p>e. If voltage observed at A1Q14 or AIQ12 collector is below +0.3 Vdc check voltage at A1A4C-14.</p> <p>(1) If A1A4C-14 is above +3.0 Vdc proceed to item 10f.</p>

Sequence No.	Doe Test	Trouble Symptom	Probable Cause	Corrective Action
9	5-12	<p>a. Incorrect voltage at collector of AIQ18.</p> <p>b. Incorrect voltage at A1A4A-5 or AA4B-9.</p> <p>c. Incorrect voltage at A1A5A- or A1ASB--7.</p> <p>d. Incorrect voltage at A1ASA-, A1ASB7 or A1A8C-11. A1A3C.</p> <p>e. Incorrect voltage at A1 pin 13, .14 or 15.</p>	<p>Defect in sequencing circuit. and AIQ13.</p> <p>Defect in NAND gates. and inputs to them.</p> <p>Defect in NAND gates. inputs to them.</p> <p>Defect in NAND gates.</p> <p>Defect in NAND gates.</p>	<p>(2) If A1A4C-14 is below +3.0 Vdc check AIA4C and inputs to A1A4C.</p> <p>f. If voltage observed at A1A4C-14 is above +3.0 Vdc check voltage at A1ASD-14.</p> <p>(1) If A1A3D-14 is below +0.3 Vdc proceed to it&amp;n log.</p> <p>(2) If A1A3D-14 is above +0.3 Vdc check A1A3D and inputs to A1AiD.</p> <p>g. If voltage at AIA3D-14 is below +0.3 Vdc check A1Q7 collector voltage</p> <p>(1) If A1Q7 collector is above +10.0 Vdc proceed to item 10h.</p> <p>(2) If A1Q7 collector is below +110.0 Vdc check A1CR8, A1Q7, and A1R8.</p> <p>h. If voltage at A1Q7 is above + 10.0 Vdc observe waveform at A1Q8 collector.</p> <p>(1) If waveform at A1Q8 collector is the same as that shown in figures -2K and -2L proceed to item 11.</p> <p>(2) If waveform at A1Q8 collector is incorrect, check components associated with A1Q8 and A1Q9.</p> <p>Check AIR20, AIR21, A1CI13</p> <p>Check A1A4A-5 and AIA4B-9</p> <p>Check A1A5A-3 and A1A5B-7 and</p> <p>a. If more than one output is below + 1.0 Vdc check inputs to A1A3A, A1A3B and</p> <p>b. If only one gate has two high level inputs (above + 3.0 Vdc) check AIA3.</p> <p>c. If more than one gate has two high level inputs (above +3.0 Vdc) check A1A1 and A1A2.</p> <p>a. If low voltage output circuit does not correspond to the low voltage output from A1A3a, A1A3B and A1A3C check the components in the related circuits.</p> <p>b. If there is no low voltage output check the components in the circuit related to the low voltage output from AIA3A, A1A3B and AIA3C.</p>

<i>Sequence No.</i>	<i>Doe Test</i>	<i>Trouble Symptom</i>	<i>Probable Cause</i>	<i>Corrective Action</i>
	f.	(1) Incorrect voltage at pin 13, 14 or 15 of circuit board A1 when one gate is grounded.	Defect in WAND gates.	If output voltage does not go high when input to low voltage circuit is grounded in TEST CHART step 6a and b, check circuits related to NAND gate (A1A3A, A1ASB, or A1ASC) being checked
		(2) Incorrect voltage at pin 13, 14, or 15 of circuit board A1 when remaining gate is grounded.	Defect in NAND gates.	If output voltage does not go low when input to high voltage circuit is grounded in TEST CHART step &c and d, check circuits related to NAND gate (A1A3A, A1A3B, or A1A3C) being checked.
	g.	Incorrect voltage at collector of A1Q13 when RF power is	Defect in sequencing circuit.	Check A1R20, A1R21, and AIQ.13.
	h.	Incorrect voltage at A1A4A6.	Defect in NAND gates or servo rotation logic	Check inputs A1A4A-1, 2, and 3. If all are high check A1A4. Note. A1A4A-5 should be below +0.3 Vdc only when A4A-1 is high and A4B-8 is low.
	i.	Incorrect voltage at A1A4B-9.	Defect in NAND gates or servo rotation logic.	Check inputs A1A4B-6, 7, and 8. If any are low check A1A4. Note. Voltages should be high only when A4B-8 is low.
	j.	Incorrect voltage at	Defect in NAND gates.	Check A1A5. A1A5A-8.
	k.	Incorrect voltage at A1A5B-7.	Defect in WAND gates.	Check A1A5.
	l.	(1) Incorrect waveforms at A1A3A3, A1A3B-7, or A1A3C-1.	Defect in NAND gates or flip-flops.	If any waveforms are missing, check A1A3. If waveforms are not properly sequenced, check A1A1 and A-1-2.
		(2) Incorrect waveforms at A1ASA-3, A1A8B-7, or AA1 C-11 when limit switch 52 is tripped.	Defect in flip-flops.	Check AQA1 and AIA2.
	m.	Incorrect waveforms at pins 13, 14, and 15 of circuit board A1.	Defective sequencing logic circuits.	Check AQ1, AIQ2, AIQ3, s AIQ4, A~1Q5, A1Q6 and assisted circuits. If no output check AICRI.
10	5-13	Note. This procedure is performed on antenna model 437SAA only.		
	a.	Incorrect voltage at A1A6B-7.	Defect in A1A6. Check A1A6.	
	b.	Incorrect voltage at A1A6C-11	Defect in A1A6. Check A1A6.	
	c.	Incorrect voltage at AIQ16 collector.	Defect in A1Q16.	Check AIQ16 and A1RA1.
	d.	Incorrect voltage at A1A6A43.	Defect in A1AS	Check A1A6.
	e.	Incorrect voltage at A.QIS collector.	Defect in AIQ15.	Check AIQ1S and A1R, 7.

Sequence No.	Doe Test	Trouble Symptom	Probable Cause	Corrective Action
f.		Incorrect voltage at A1A6B-7 when MANUAL TUNE switch is set to DECREASE FREQUENCY.	Defect in A1A6.	Check A1A6 and A1R32.
g.		Incorrect voltage at A1Q16 collector when MANUAL TUNE switch is set to DECREASE FREQUENCY.	Defect in AIQ16.	Check AIQ16 and A1R28.
h.		Incorrect voltage at A1A6B-7 when MANUAL TUNE switch is set to INCREASE FREQUENCY.	Defect in AIA6.	Check AIA6 and A1CR26.
i.		Incorrect voltage A11 AIA6, C- 1 when MANUAL TUNE switch is set to INCREASE FREQUENCY.	Defect in A1A6.	Check AIA6 and A1R11.
j.		Incorrect voltage at A1A6A-3 when MANUAL TUNE switch is set to INCREASE FREQUENCY.	Defect in A1A6.	Check A1A6.
k.		Incorrect voltage at AIA16 collector when MANUAL TUNE switch is set to INCREASE FREQUENCY.	Defect in AIQ15.	Check AIQ16 and AIR30.

**Section II. General Support Repair and Replacement**

**4-6. General**

a. Careless or incorrect repair or replacement of parts can cause more damage and trouble than the original defect. Before unsoldering a part, note the position of the leads and parts involved. Make notes and sketches of the original location and placement of parts and lead wires to assure proper lead wire dress and parts location to duplicate the original condition. This procedure also minimizes the possibility of wiring errors.

b. When soldering transistors, use a heat sink (a pair of pliers or a large alligator clip) between the transistor leads and the connection terminals. Transistors are sensitive to heat. Overheating during soldering operations may change their characteristics or permanently damage them. Use a low wattage iron to solder or unsolder all connections, except ground connections made directly to the chassis. For ground connections to the chassis, use a 100-watt iron. When soldering, apply the soldering iron only long enough to assure a good joint. When unsoldering, do not apply the soldering iron to the joint any longer than necessary to melt the solder. Hasten cooling by dipping a soft brush in alcohol and applying it to the joint.

c. In replacing components, refer to the MCN Effectivity List (paragraph 1-5) for information on

differences in individual units.

**4-7. Disassembly of Coupler Assembly (Fo 6-6)**

a. *Removal of Components on Servo Amplifier Card AI.*

(1) Remove cover MP11 by loosening four screws MP11H4 and two screws MP11H2.

(2) Separate servo amplifier card AI from backing plate MP21 by removing five screws AI-H5 and one screw AIH1. Nut and washer MP6H1 and loop clamp MP6 are attached to screw AIH1.

(3) Remove the desired component.

**NOTE**

If removal of servo amplifier card AI is necessary, unsolder and code all wires attached to the card.

b. *Removal of Components from Phase Discriminator Board A2.*

(1) Remove four screws, lockwashers and nuts A2H4.

(2) Carefully position phase discriminator board A2 away from the unit to obtain access to components on the board.

**NOTE**

If it is necessary to remove phase discriminator board A2, unsolder and code all wires attached to the board. Remove four screws, lock-washers and not A2H4 that hold discriminator to coupler assembly.

*c. Removal of Coils L1 and L2.*

(1) Remove core flux generator holders MP-16 and MP17 by loosening and removing four screws, flat washers, and lockwashers MP54H.

(2) Remove plate L4 by loosening one screw and lockwasher L4H1 and two screws MP23H1 and MP22H1 and then unsoldering the end of L4 from antenna element MP13.

(3) Remove four screws MP5H4 and carefully position flux generator bracket MP5 away from the base plate.

(4) Remove four screws and lockwashers MP2H4 and separate flux generator base MP2 from the base plate.

(5) Coil L1 or L2 is removed from flux generator base MP2 by removing two screws, lockwashers and flat washers L1 or L2H2.

*d. Removal of Capacitor A3C1. (fig. 4-1)*

**NOTE**

Capacitor A3C1 may be removed without gear train assembly A3.

(1) Turn gear train until spring pin C1H1 in the shaft of capacitor C1 can be removed.

(2) Place a piece of paper between a set of mating gears and remove spring pin C1H1.

(3) Slowly allow shaft of capacitor C1 to run into capacitor by holding a gear and removing paper.

(4) Loosen four screws and lockwashers C1H4 and separate C1 from casting.

*e. Removal of Antenna Element Assembly. (FO 64)*

(1) Remove the solder between plug P1 and nut MP25H1 using a soldering iron

(2) Unscrew and remove plug P1 and nut MP25H1. Slide flat washer MP25H1 and teflon spacer MP25 off the antenna element MP13.

(3) Loosen four screws MP5H4 in flux generator bracket MP5 and position the coreflux generator holders MP16 and MP17 so toroidal cores E6 and E7 can be removed from antenna element MP13.

(4) Unsolder plate L4 from antenna element and remove the excess solder.

(5) Cut lacing cord, unsolder the L3 wires, and slide toroidal core L3E1 from antenna element MP13.

(6) Unscrew core spacer MP24 from connector J 1.

(7) Unsolder and remove antenna element MP13 from connector J1.

(8) Connector J1 is secured to the base plate with a nut and shake washer.

*f. Removal of Gear Train Assembly A3. (FO 6-6)*

(1) Remove access panel MP18 by loosening three screws MP18H3 and five screws MP18H5.

(2) Remove the screw, washer and rim clench clamp assembly MP7 that is next to base plate MP20.

(3) Remove the two screws and lockwashers MP12H3 and the three screws and lockwashers MP12H3 that are attached to cover MP12

(4) Remove cover MP 11 by loosening four screws MP11H4 and two screws MP11H2.

(5) Separate servo amplifier card A1 from backing plate MP21 by removing five screws A1H5 and one screw A1H1. Nut and washer MP6H1 and loop clamp MP6 are attached to screw A1H1

(6) Remove four screws MP21H4 from backing plate MP21 and carefully position backing plate MP21 away from control motor B1.

(7) Remove the remaining three screws, washer, and rim clench clamp assemblies MP7 on control motor B1.

(8) Remove four screws A3H4 and lockwashers A3H6 and two screws A3H2 and lockwashers A3H6 and separate gear train assembly from base plate MP20.

*g. Disassembly of Gear Train Assembly A3. (fig. 4-1)*

(1) Removal of gears MP6 and MP8.

(a) Use a pin punch to remove spring pins MP6H1 and MP8H1

(b) Slide drive shaft MP11 out of casting and remove gears MP6 and MP8 and shaft space MP 13. The annular ball bearings MP1 and MP2 are pressed into the casting

(2) Removal of gear MP7 and shaft MP10.

(a) Use a pin punch to remove spring pin MP10H1.

(b) Remove retaining ring MP10H1, slide shaft MP10 from casting, and remove gear MP7 and pinion spacer MP12 Annular ball bearings MP3 and MP4 are pressed into the casting.

(3) Refer to paragraph 4-7d for removal of capacitor A3C1.

(4) For reassembly instructions refer to paragraph 4-8e.

**4-8. Assembly of Coupler Assembly**

*a. Replacement of Gear Train Assembly A3. (FO 6-6)*

(1) Position gear train assembly A3 on base plate MP20, inserting the shaft of control motor B1 through the hole in the casting that allows the shaft to engage gear MP6 (fig. 4-1)

(2) Secure control motor B1 to gear train assembly A3 with the two screws, washer, and rim clench clamp assemblies MP7 that are away from base plate MP20.

(3) Secure gear train assembly A3 to base plate MP20 using four screws A3H4 and lockwashers A3H6

and two screws and lockwashers A3H2. Attach the two remaining screws, washers, and rim clench assembly MP7 to control motor B1

(4) Position backing plate MP21 in place and secure with four screws MP21H4.

(5) Position servo amplifier card AI against backing plate MP21 and secure with five screws AIH5 and one screw A1H1. Secure loop clamp MP6 to screw A1H1 with nut and washer MP6H1.

(6) Secure cover MP 11 to backing plate MP21 with four screws MP11H4 and two screws MP11H2.

(7) Secure access panel MP18 using three screws MP18H3 and five screws MP18H5.

*b. Replacement of Capacitor A3C1.*

(fig. 4-1)

(1) Position capacitor C1 on casting and secure with four screws and lockwashers C1 H4. Position bearing MP5 in place.

(2) Turn gear train to pull the shaft of capacitor C1 out. When the hole in the end of the shaft is clear, place a piece of paper between a set of mating gears.

(3) Insert spring pin C1H1 in the hole at the end of the capacitor shaft. Push the pin until the end of the gear side of the shaft will rest on the bearing. The other end of spring pin C1H1 should be low enough to trip the arms of switches S1 and S2. Remove the paper between the gears.

*c. Replacement of Antenna Element Assembly (FO 6-6)*

(1) Secure J1 to base plate MP20 with nut and shake washer.

(2) Place glyptal on threads of connector J1 and screw core spacer MP24 on connector J1

(3) Insert lug of J1 into slot of antenna element MP13 and solder.

(4) If toroidal core L3E1 and wires of coil L3 are not bonded to spacer MP24, they are to be cemented together during test. Position this core next to core spacer MP24.

(5) Place toroidal cores E6 and E7, teflon spacer MP25, flat washer and nut MP25H1 on antenna element-ment MP13.

(6) Position the core flux generator holders MP16 and MP17 in flux generator bracket MP5 and secure with two screws, lockwasher, and flat washer assemblies MP5H4 in each.

(7) Spread a small amount of heat sink compound (Dow Corning DC340) between and on the outside of toroidal cores E6 and E7.

(8) Place the curved portions of the

coreflux generator holders MP16 and MP17 over toroidal cores E6 and E7. Tighten the four screws MP2H4 so the antenna element MP13 is centered in E6 and E7.

(9) Tighten nut MP25H1 and screw plug P1 on antenna element MP13. The distance between the bot-tom of base plate MP20 and the nut portion of P1 should be 3 inches. Apply solder between P1 and not MP25H1.

(10) Solder curved end of plate L4 on antenna element-ment MP13. Secure plate L4 by tightening two screws MP22H1 and MP23H1 and on screw L4H1.

*d. Replacement of Coils L1 and L2*

(FO 6-6)

(1) Secure coils L1 and L2 to flux generator base MP2 with screws lockwashers, and flat washers L1H2 and L2H2.

(2) Mount MP2 on base plat MP20 and secure with four screws and lockwashers MP2H4.

(3) Secure flux generator bracket MP5 to base plate MP20 with four screws MP5H4.

(4) Slide plate L4 through MP5 and solder curved end to antenna element MP13.

(5) Secure plate L4 in place with two screws MP23H1 and MP22H1 and one screw and lockwashers L4H1.

*e. Reassembly of Gear Train Assembly A3.*

(FO 6-6)

(1) Replacement of gears MP6 and MP8.

(a) Press annular ball bearings MP1 and MP2 in place on the casting.

(b) Position gears MP6 and MP8 and shaft spacer MP13 in casting and slide shaft MP11 in place.

(c) Secure each gear to the shaft with a setscrew when a new hole is drilled. If a new shaft MP1 1 is used, drill a 1/16-inch hole in each end of the shaft, using the hole in each gear as a guide.

(d) Secure each gear to the shaft, using spring pins MP6H1 and MP8H1. Remove setscrews.

**NOTE**

If the old shaft MP11 is used, larger spring pins will be required to assure the gears are securely positioned on the shaft.

(2) Replacement of gear MP7 and shaft MP10

(a) Press annular ball bearings MP3 and MP4 in place on the casting.

(b) Position gear MP7 and pinion spacer MP12 in casting and slide shaft MP10 in place.

(c) Secure gear MP7 to the shaft using the setscrew. If a new shaft MP10 is used, drill a 1/16-inch hold in the shaft, using the hole in the gear as a guide.

(d) Secure gear MP7 to shaft MP10 using spring pin MP10H1. Remove the setscrew.

**NOTE**

If the old shaft MP10 is used, larger spring pin Is required to assure the gear Is securely positioned on the shaft.

(3) Refer to paragraph 4-8d. for replacement of A3C1.

f. *Replacement of Phase Discriminator Board A2.*

(1) Resolder all wires. Insure that wires are connected to proper terminals.

(2) Replace four screws, lockwashers, and

nuts A2H4 that secure discriminator board A2 to coupler assembly.

g. *Replacement of Servo Amplifier Card A1.*

(1) Resolder all wires. Insure that wires are connected to proper terminals.

(2) Attach servo amplifier card to A1 to backing plate MP21 by replacing five screws A1H1. Nut and washer MP6H1 and loop clamp MP6 are attached to screw A1H1.

(3) Replace cover MP11 by tightening four screws MP11H4 and two screws MP11H2.

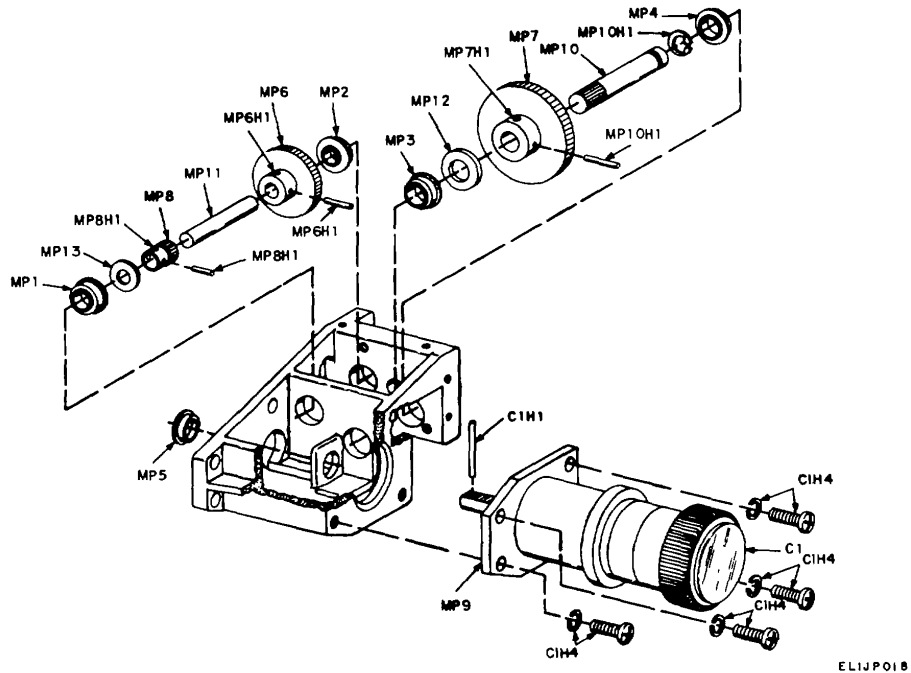

Figure 4-1. Gear train assembly A3, exploded view.



CHAPTER 5

PERFORMANCE STANDARDS

**5-1. Applicability of Performance Standards**

The tests outlined in this chapter are designed to measure the performance capability of a repaired equipment. Equipment that is to be returned to stock should meet the standards given in these tests.

**5-2. Applicable References**

a. *Repair Standards.* Applicable procedures of the depots performing these tests and the general standards for repaired electronic equipment given-en in TB S1G 355-1. TB SIG 355-1, and TB SIG 355-2, and TB SIG 355-3 form a part of the re-requirements for testing this equipment.

b. *Technical Manuals.* The other applicable technical manual is TM 11-5821-284-20.

c. *Modification Work Orders.* Perform work specified by modification work orders (MWO's) pertaining to this equipment before making the tests specified. DA Pam 310-7 lists all available MWO's.

**5-3. Test Facilities Required**

The following equipments and materials, or suit-able equivalents, will be employed in determining compliance with specific standard.

- a. Test Set, Antenna AN/ARM-115.
- b. Generator, Signal AN/USM-44A.
- c. Oscilloscope, AN/USM-281.

- d. Multimeter ME-26B/U.
- e. Amplifier, Power (Boonton 230A, FSN 6625-942-3042).
- f. Power Supply.
- g. Resistor, fixed, 6850 ohms or 5600 ohms + 10% ¼-W power rating.

**NOTE**

When testing antenna model 437S-1B replace R9 on circuit board AI with a 5600-ohm resistor or connect a 6850-ohm resistor in parallel AIR9. Remove the resistor when testing is complete.

**5-4. Phase Discriminator output Test**

- a. *Test Equipment.*
  - (1) Test Set, Antenna AN/ARM-115.
  - (2) Generator, RF Signal AN/USM-44A.
  - (3) Multimeter ME-26B/U.
  - (4) Amplifier, Power Boonton 230A.
- b. *Test Connections and Conditions.* Connect the equipment as shown in figure 5-1. Turn on the equipment and allow 5-minute warmup before proceeding.
- c. *Procedure.*

Step	Test equipment control settings	Test procedure	Performance standard
1	AN/ARM-115: METER FUNCTION: OFF. MV ADJUST: fully ccw. MANUAL TUNE: OFF. AN/USM-44A: Adjust for 30-MHz output, maximum power. Power Amplifier: Adjust for 30MHz output, maximum power. ME-26B/U: Adjust to read 1.0 Vdc.	Measure dc voltage between FL1 and FL5, positive Lead to FL1.	FL1 is 0.4 to 1.0 volt positive with respect to FL5

Step	Test equipment control settings	Figure ref.	Test procedure	Performance standard
2	Readjust AN/USM-44A and Power Amplifier for 50MHz output, maximum power	Fig 5-6 (1)	Same as step 1	Same as step 1
3	Readjust AN/USM-44A and Power Amplifier for 76-MHz output, maximum power	Fig 5-6 (1)	Same as step 1	Same as step 1
<b>5-5. Servo Loop Test</b>				
<i>a. Test Equipment</i>				
(1)	Test Set, Antenna AN/ARM-1 15.			
(2)	Generator, RF Signal AN/USM-44A.			
(3)	Oscilloscope, AN/USM-281.			
(4)	Amplifier, Power Boonton 230A			
(5)	Power Supply.			
			<i>b. Test Connections and Conditions.</i> Connect the equipment as shown in figure 5-2. Turn on the equipment and allow 5-minute warmup before proceeding.	
			<i>c. Procedure.</i>	

Step	Test equipment control settings	Figure ref.	Test procedure	Performance standard
1	AN/ARM-115 METER FUNCTION OFF MV ADJUST. OFF MANUAL TUNE. OFF AN/USM-44A Adjust for 30MHz output, maximum power Power Amplifier Adjust for 30-MHz output, maximum power. AN/USM-160 Adjust to observe waveform shown in figure 6-4X Power Supply Adjust for +27.5 Vdc	Fig 5-7 (TP 17)	Observe waveform at J2-K Unit runs continually, positioning vacuum variable capacitor C1 from maximum to minimum	Waveform is same as that shown in figure 6-4X
2	Readjust AN/USM 44A and Power Amplifier for 50MHz output, maximum power	Fig 5-7 (TP-17)	Same as step 1	Same as step 1.
3	Readjust AN/USM44A and Power Amplifier for 76-MHz output, maximum power	Fig 5-7	Same as step 1	Same as step 1.
<b>5-6. Fine Tune Mode Test</b>				
<i>a. Test Equipment.</i>				
(1)	Test Set, Antenna AN/ARM-115.			
(2)	Oscilloscope, AN/USM-281.			
(3)	Power Supply.			
<i>b. Test Connections and Conditions.</i>	Connect the equipment as shown in figure 3-2. Connect positive		lead of 0-500 MV OUTPUT to FLI and negative lead to FLS. Turn on the equipment and allow 5-minute warm-up before proceeding.	
			<i>c. Procedure.</i>	

Step	Test equipment control settings	Figure ref.	Test procedure	Performance standard
1	AN/ARM-115. METER FUNCTION +0 to 500 mV MV ADJUST. Adjust for + 100 mV.	Fig. 5-6 1 (TP-16)	Ground FLA and observe waveform at FL6	Waveform Is the same as that shown in figure 6-4U.

Step	Test equipment control settings	Figure ref.	Test procedure	Performance standard
	MANUAL TUNE: OFF. AN/USM-140' Adjust to observe waveform shown in figure 6-4U. Power Supply. Adjust for +27.5 Vdc.			
<b>5-7.</b>	<b>Servo Gain Test</b>			
	a. <i>Test Equipment.</i> (1) Test Set, Antenna AN/ARM-115. (2) Oscilloscope, AN/USM-281. allow 5-minute warmup before proceeding. (3) Power Supply.			
	b. <i>Test Connections and Conditions.</i> Connect the equipment as shown in figure 5-2. Connect positive lead of 100 MV OUTPUT to FL1 and negative lead to FL5. Turn on the equipment and			
	c. <i>Procedure.</i>			

Step	Test equipment control settings	Figure ref.	Test procedure	Performance standard
1	AN/ARM-115. METER FUNCTION +0 to 500 mV. MV ADJUST: Adjust for +100 mV. MANUAL TUNE: OFF. AN/USM-1140: Adjust to observe waveforms shown in figures 6-4Y and 6-4Z. Power Supply Adjust for +27.5	Fig. 5-7 (TP-17)	Ground FL4 and observe waveform at JZK.	Waveform is the same as that shown in figure 6-4Y T2 is 9.5 ±3.5 ms.
2	Turn AN/ARM-115 METER FUNCTION to -0 to 500 mV and adjust for -100-mV output.	Fig. 5-7 (TP-17)	Observe waveform at J2K	Waveform is same as that shown in figure 6-4Z. T2 is 9.5 f3.5 ms.

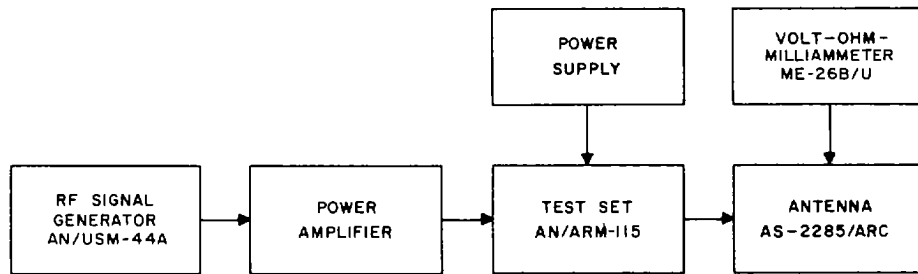

E L I J P 019

Figure 5-1. Test connections, phase discriminator output test.

<b>5-8.</b>	<b>Receive/Transmit Logic Test</b>			
	a. <i>Test Equipment.</i> (1) Test Set, Antenna AN/ARM-115. (2) Power Supply.			
	b. <i>Test Connections and Conditions.</i> Connect the equipment as shown in figure 5-3. Connect positive			'lead of 100 MV OUTPUT to FL1 and negative lead to FL5. Turn on the equipment and allow 5-minute warmup before proceeding.

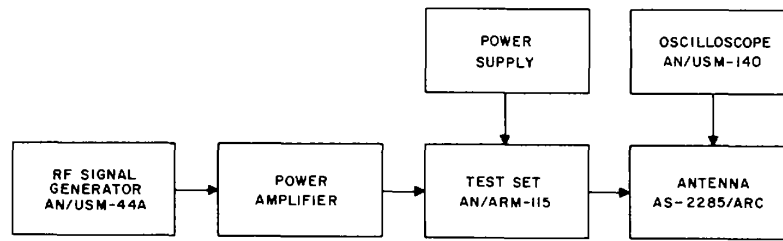

ELIJP020

Figure 5-2. Test connections, servo loop test.

c. Procedure.

Step	Test equipment control settings	Figure ref.	Test procedure	Performance standard
1	AN/ARM-115: METER FUNCTION: +0 to 500 mV. MV ADJUST: Adjust for +100 mV. MANUAL TUNE OFF. Power Supply: Adjust for +27.5 Vdc.	Fig. 5-6 (1)	Ground FL4 and observe for cycling.	Antenna cycles normally.

5-9. Homing Circuit Test

a. Test Equipment.

- (1) Test Set, Antenna AN/ARM-115.
- (2) Power Supply.

b. Test Connections and Conditions. Connect the equipment as shown in figure 5-3. Turn on the equipment and allow 5-minute warmup before proceeding.

c. Procedure.

Step	Test equipment control settings	Figure ref.	Test procedure	Performance standard
1	AN/ARM-115: METER FUNCTION: 10 to 500 MV MV ADJUST: 100 MV MANUAL TUNE: OFF. Power Supply: Adjust for +27.5 Vdc.	Fig. 5-6 (2)	Manually trip limit switch S2. Release S2.	Variable capacitor C1 runs completely out
2	Same as step 1.	Fig. 5-6 (2)	Manually trip limit switch S1. Release S1.	Variable capacitor runs completely in.

5-10. Power Supply Test

a. Test Equipment.

- (1) Test Set, Antenna AN/ARM-115.
- (2) Multimeter ME-26B/U.
- (3) Power Supply.

b. Test Connections and Conditions. Connect the equipment as shown in figure 5-4. Turn on equipment and allow 5-minute warmup before proceeding.

c. Procedure.

Step	Test equipment control settings	Figure ref.	Test procedure	Performance standard
1	AN/ARM-115: METER FUNCTION OFF. MV ADJUST: fully ccw. MANUAL TUNE- OFF. ME-26B/U: Adjust to read dc volts; 28 Vdc maximum. Power Supply: Adjust for +27.5 Vdc.	Fig. 5-8	Measure with ME-26B/U for +27.5 Vdc at pin 2 of circuit board A1.	+27.5 Vdc <u>-5%</u>

Step	Test equipment control settings	Figure ref.	Test procedure	Performance standard
2	Same as step 1.	Fig. 5-8	Measure with ME-26B/U for +6.2 Vdc at pin 5 of circuit board A1.	+6.2 Vdc. 5%
3	Same as step 1.	Fig. 5-10	Measure with ME-26B/U for +13.7 Vdc at A1AR1-10.	+13.7 Vdc t5%
4	Same as step 1.	Fig. 5-8	Measure with MI'-2biB/U for +5.1 Vdc at pin 8 of circuit board A;	+5.1 Vdc. -5%

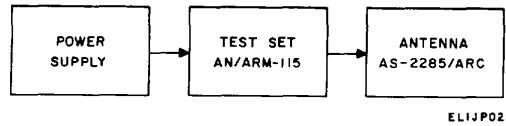

Figure 5-3. Test connections, receive/transmit logic and homing circuit tests.

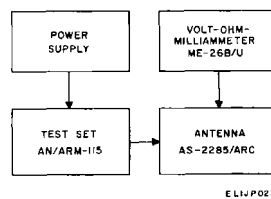

Figure 5-4. Test connections, power supply test.

**5-11. Pulsing Circuit Test**

*a. Test Equipment.*

- (1) Test Set, Antenna AN/ARM-115.
- (2) Oscilloscope, AN/USM-281.
- (3) Power Supply.

*b. Test Connections and Conditions.*

Connect equipment as shown in figure 3-2. Connect positive lead of 100 MV OUTPUT to FL1 and negative lead to FL5. Turn on the equipment and allow 5-minute warmup before proceeding.

*c. Procedure*

Step	Test equipment control settings	Figure ref.	Test procedure	Performance standard
1	AN/ARM-115: METER FUNCTION: +0 to 500 mV. MV ADJUST: Adjust for +100 mV. MANUAL TUNE., OFF. AN/USM-281 :Adjust controls to observe waveforms shown in figures 64A and 6-4B. Power Supply. Adjust for +27.5 Vdc.	Fig. 56 6Q and 5-10 (TP-1)	Manually trip limit switch S1 and observe waveform at A1AR1-9	Waveform is same as that shown in figure 6-4A.
2	Same as step 1 except set AN/ARM-115 METER FUNCTION to -0 to 600 mV and adjust for -100-mV output.	Fig. 5-6 and 5-10 (TP-1)	With limit switch S1 still tripped, observe waveform ;it 41 R1--9	Waveform is same as that shown in figure 64B.

**5-12. Sequencing Circuit Test**

*a. Test Equipment.*

- (1) Test Set, Antenna AN/ARM-115.
- (2) Multimeter ME-26B/U.

- (3) Oscilloscope, AN/USM-281.
- (4) Generator, RF Signal AN/USM-44A.
- (5) Amplifier, Power Boonton 230A.

(6) Power Supply.  
 b. *Test Connections and Conditions.*  
 Connect equipment as shown in figure 5-5. Do not connect the AN/USM-44A and power amplifier until di-

rected. Turn on the equipment and allow 5-minute warmup before proceeding.  
 c. *Procedure.*

Step	Test equipment control settings	Figure ref.	Test procedure	Performance standard
1	AN/ARM-115: METER FUNCTION OFF. MV ADJUST. fully ccw. MANUAL TUNE: OFF. ME-26B/U: Adjust to read dc volts, 28 Vdc maximum. Power Supply: Adjust for +27.5 Vdc.	Fig. 5-8	Measure dc voltage at collector of A1Q13.	Less than +0.3 Vdc
2	Same as step 1.	Fig. 5-9	Measure dc voltage at A1A4Ai and A1A4B-9.	More than +3.0 Vdc.
3	Same as step 1.	Fig. 5-9	Measure dc voltage at A1ASA-3 and A1A5B-7.	Less than +0.3 Vdc.
4	Same as step 1.	Fig. 5-8 and 5-9 (TP-10, TP-11, TP-12)	Measure dc voltage at A1A3A-3, A1A3B-7 and A1A3I111.	Less than +1.0 Vdc on one output. More than +3.0 Vdc on other two
5	Same as step 1.	Fig. 5-8 (TP-13, TP-1-4, TP-1 5)	Measure dc voltage at pins 13, 14, and 15 of circuit board A1.	Less than +1.0 Vdc in same circuit as low voltage measured in step 4. More than +27.0 Vdc in same circuits in which high voltage was measured In step 4.
6	Same as step 1.	Fig. 5-8 and 5-9 (TP-100 TP-11 TP-12)  Fig. 5-8 (TP-13, TP-9-4, TP-15)  Fig. 5-8 (TP-13, TP-14, TP-15)  Fig. 5-8 (TP-13, TP-14, TP-15)	a. Ground one input on the gate with low output voltage (A1A3A3, A1A3B7, or A1A3Cil). b. Check related output at pins 13, 14, and 15 of circuit board A1. c. With one input on gate in step a still grounded, ground output on one of remaining gates. Check related output at pins 13, 14, and 15. d. Remove ground applied to gate output in step c and ground remaining gates. Check related output at pins 13, 14, and 15.	a. Output changes to more than +3.0 Vdc. b. Output changes to more than +3.0 Vdc. c. Output changes to less than +1.0 Vdc. d. Output changes to less than +1.0 Vdc.
7	Same as step 1, except connect AN/USM44A and Power Amplifier to AN/ARM-115 and adjust for 0-MHz output, maximum power.	Fig. 5-8	Measure dc voltage at collector of A1Q1S.	More than +3.0 Vdc.
8	Same as step 7.	Fig. 5-8 and 5-9	Measure dc voltage A1A4A-5.	Less than +0.3 Vdc.
9	Same as step 7.	Fig. 5-8 and 5-9.	Measure dc voltage at A1A4B-9.	More than +3.0 Vdc.

Step	Test equipment control settings	Figure ref.	Test procedure	Performance standard
10	Same as step 7.	Fig. 5-8 and 5-9	Measure de voltage at A1A5A3.	More than +3. 0 Vdc.
11	Same as step 7.	Fig. 5-8 and 5-9	Measure dc voltage at A1A5B-7.	less than +0. 3 Vdc.
12	Same as step 7, except adjust AN/USM-281 to observe waveforms shown in figure 6-4Q.	Fig; 5-9 and 5-8 (TP-10 TP-119 TP-12)	Observe waveforms at A1A3A3, A1A3B7 and A1A3C11. Use output at A1A3A3 to synchronize AN/USM-140.	a. Waveforms are same as shown in figure 6-4Q.
13	Same as step 12.	Fig. 5-8 (TP-13 TP-14, TP-15)	b. Manually trip limit switch S2 and observe waveforms at AfA3A3, A1A3B-7, and AqA3C-11.	b. Waveforms are same as shown in figure 6-4R.
			c. Manually trip limit switch S1 and observe waveforms at pins 13, 14, and 15 of circuit board A1. Use output at pin 15 to synchronize AN/USM-140. Release limit switch S1.	a. Waveforms are same as shown in figure 6-4S
			b. Manually trip limit switch S2 and observe waveforms at pins 13, 14, and 15. Release limit switch S2.	b. Waveforms are same as shown in figure 6-4T.

**5-13. Manual Override Circuit Test**

**NOTE**

This test is performed on antenna model 437S-1A only.

a. *Test Equipment.*

- (1) Test Set, Antenna AN/ARM-115.
- (2) Multimeter ME-26B, /U.
- (3) Power supply.

b. *Test Connections and Conditions.*  
Connect equipment as shown in figure 5-5. Turn on equipment and allow 5-minute warmup before proceeding.

c. *Procedure.*

Step	Test equipment control settings	Figure ref.	Test procedure	Performance standard
1	AN/ARM-11S: METER FUNCTION: OFF. MV ADJUST' fully ccw. MANUAL TUNE: OFF. ME-26B/U: Adjust to read dc volts, 28 Vdc maximum.	Fig. 5-8 and 5-9	Measure dc voltage at A1A6B-7.	Less than +0. 3 Vdc.
2	Power Supply. Adjust for Same as step 1.	Fig. 5-8 and 5-9	Measure dc voltage at A1A6C11.	Less than +0 3 Vdc.
3	Same as step 1.	Fig. 5-8	Measure de voltage at collector of A1Q16.	Less than +0. 3 Vdc.
4	Same as step 1.	Fig. 5-8 and 5-9.	Measure dc voltage at A1AoA-3.	More than +3. 0 Vdc.
5	Same as step 1	Fig. 5-8	Measure dc voltage at collector of A1Q1iS.	More than +9. 0 Vdc.
6	Same as step 1, except set AN/ARM-115 MANUAL TUNE to DECREASE FREQUENCY.	Fig. 5-8 and 5-9	Measure de voltage at A1A6B-7.	More than +3. 0 Vdc.

Step	Test equipment control settings	Figure ref.	Test procedure	Performance standard
7	Same as step 6.	Fig. 5-8	Measure de voltage at	More than +9. 0 Vdc.
8	Same as step 6, except set AN/ARM-115 MANUAL TUNE to INCREASE	Fig. 5-9	Measure de voltage at A1A6B-7.	More than +3. 0 Vdc.
9	Same as step 8.	Fig. 5-9	Measure de voltage at A1A6C-111.	More than +3. 0 Vdc.
10	Same as step 6.	Fig. 5-9	Measure dc voltage at A11A6A-3.	Less than +0. 3 Vdc.
11	Same as step 8.	Fig. 5-8 and 5-9	Measure de voltage at col-lector of AQ15	Less than +0. 3 Vdc.

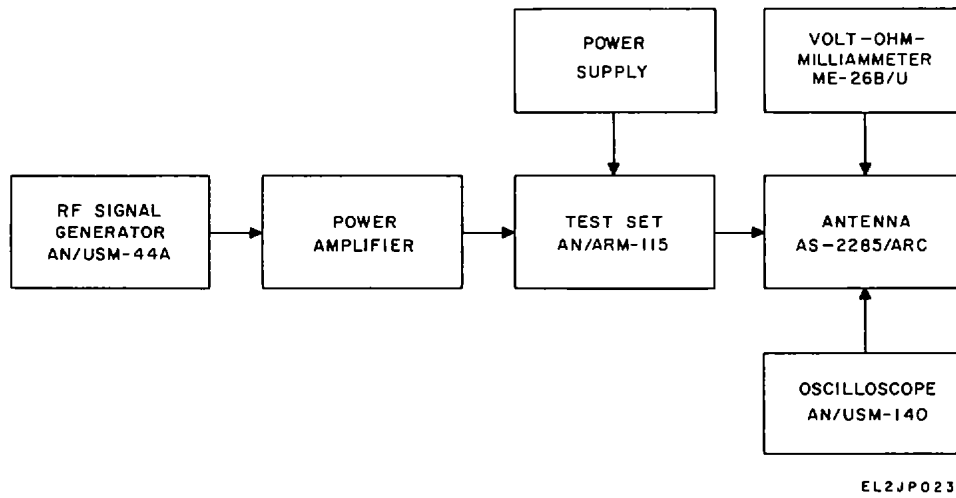

Figure 5-5. Test connections, sequencing circuit test.



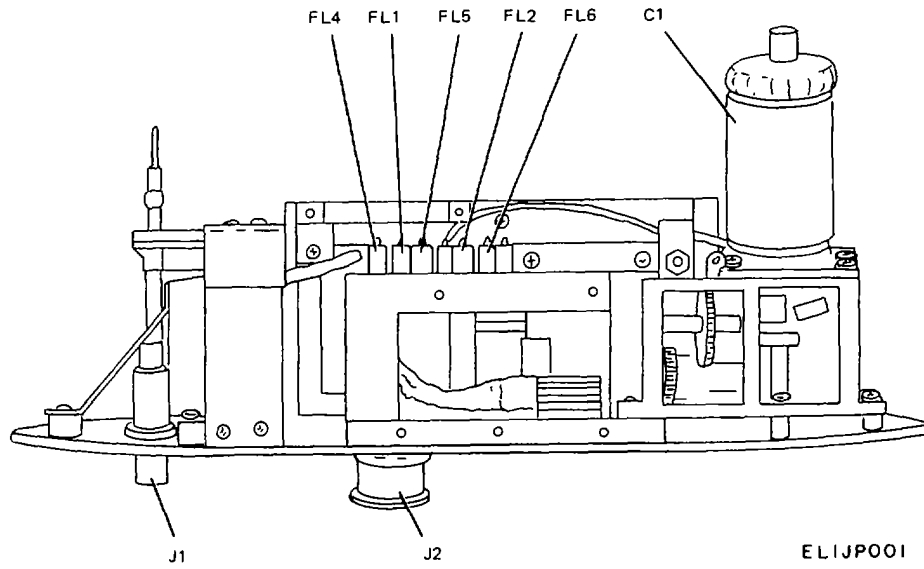

Figure 5-6 (1) 437S-1/1A/1C coupler assembly test points (sheet 1 of 2).

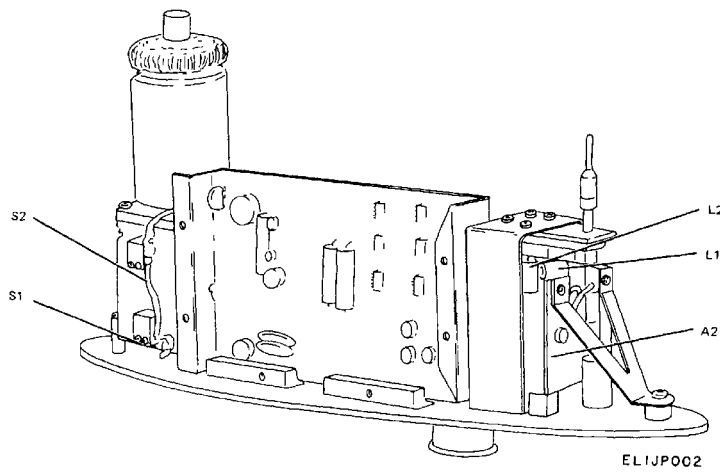

Figure 5-6 (2) 437S-1/1A/1C coupler assembly test points (sheet 2 of 2).

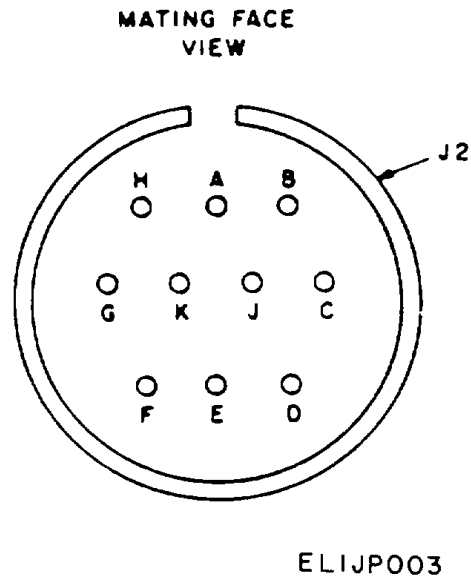

Figure 5-7. 437S-1/1A/1C coupler connection J2 test points.

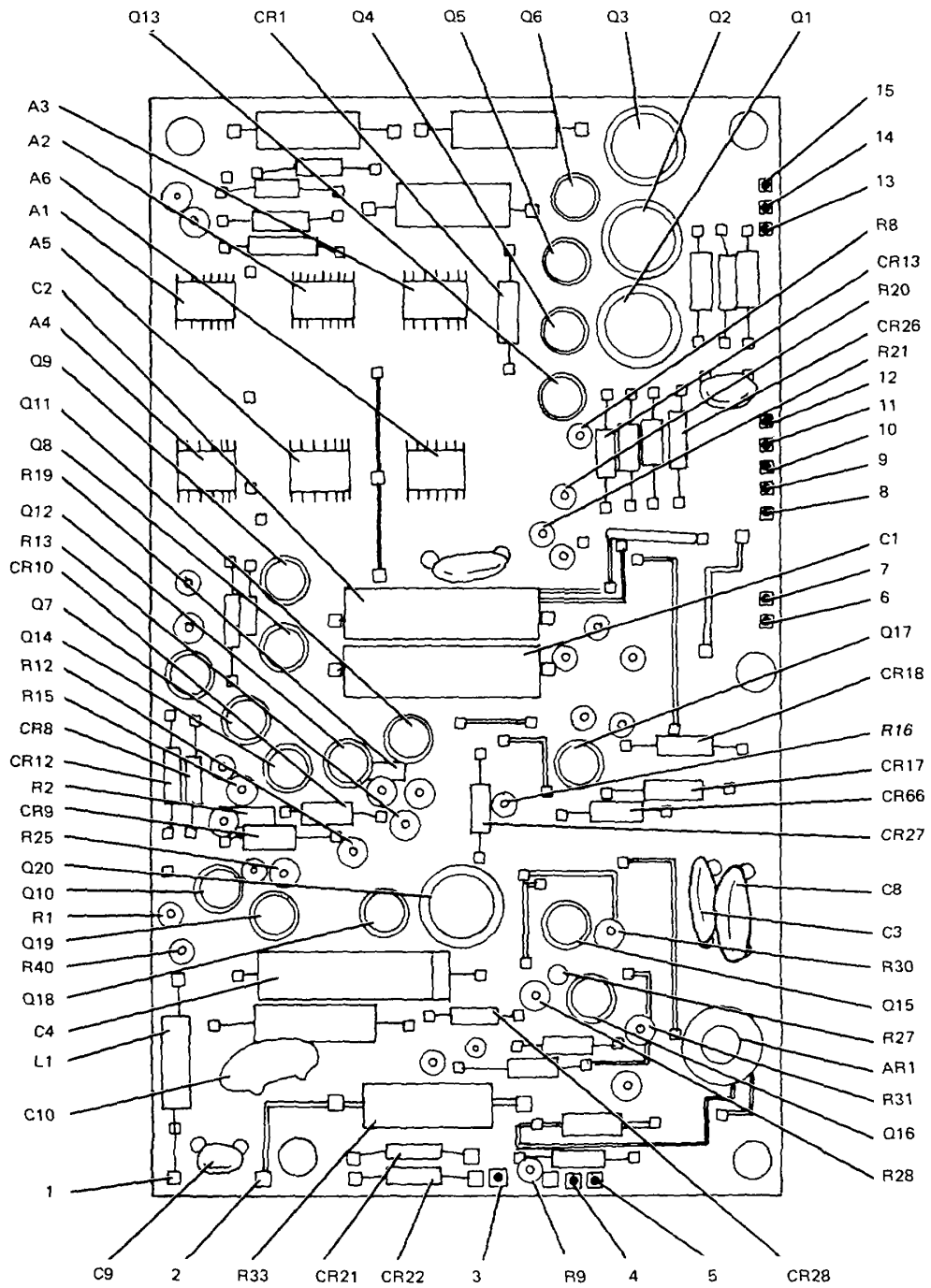
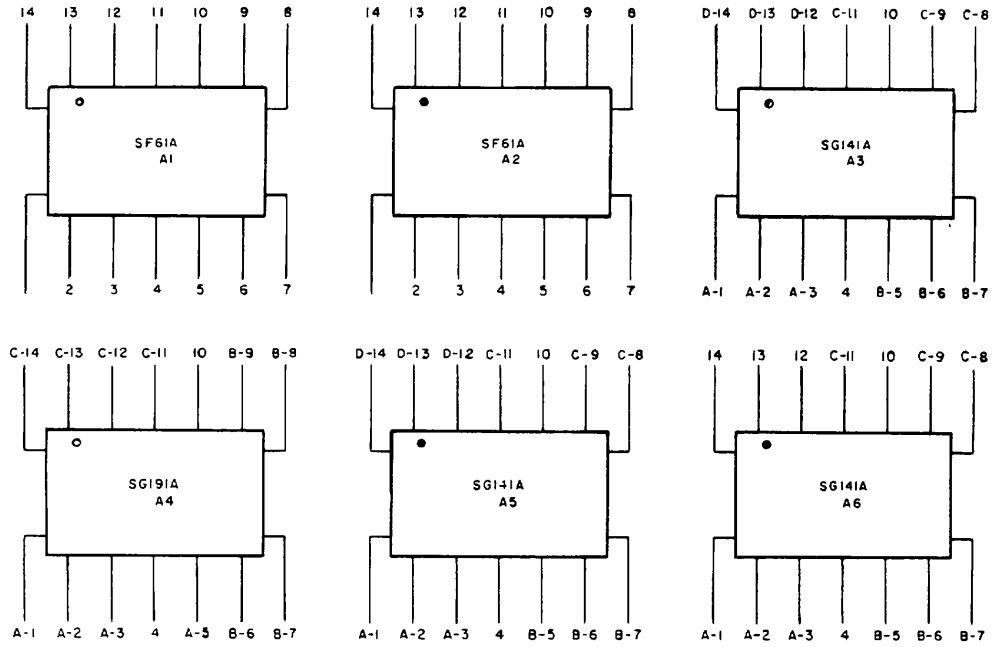

Figure 5-8. Servoamplifier circuit board A1 test points.

FL 11P004



ELIJP005

Figure 5-9. A1A1 through A1A6 flat pack test points.

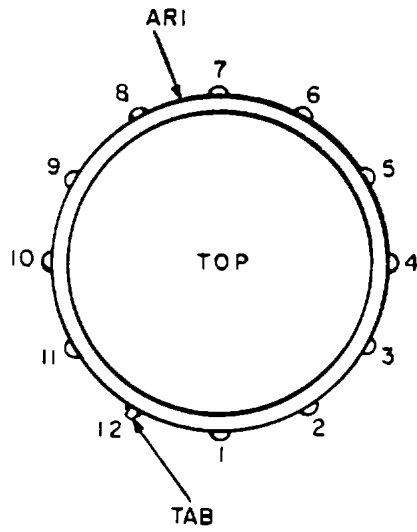

ELIJP006

Figure 5-10. Operational amplifier A1AR1 test points.

## CHAPTER 6 FINAL ILLUSTRATIONS

---

The following illustrations are provided for the use of AVUM and AV1M maintenance personnel for troubleshooting and repairing the Blade Antenna AS-2285/ARC and AS-2285A/ARC. Fold-out illustrations are located in back of manual.

<i>Fold-out No.</i>	<i>Title</i>
FO 6-1	Color code marking for M1L-STD resistors, inductors, and capacitors.
FO 6-2	AS-225A/ARC vhf/fm blade antenna (models 437S-1, -1A, -1C), schematic diagram.
FO 6-3	AS-2285/ARC vhf/fm blade antenna (model 437S-1B), schematic diagram.
FO 6-4	AS-2285/ARC and AS-2285A/ARC vhf/fm blade antenna, waveforms.
FO 6-5	Radome and coupler assembly, exploded view.
FO 6-6	Coupler assembly AI, exploded view.

## APPENDIX A REFERENCES

The following publications contain certain information applicable to the DS, GS, and depot maintenance of Blade Antenna AS-2285/ARC.

DA Pam 310-4	Index of Technical Publications. TB Sig 291 Safety Measures to be Observed when Installing and Using Whip
Antennas,	Field Type Masts, Towers, Antennas, and Metal Poles that are used with Communications, Radar and Direction Finder Equipment.
TB Sig 355-1	Depot Inspection Standard for Repaired Signal Equipment.
TB Sig 355-2	Depot Inspection Standard for Refinishing Repaired Signal Equipment
TB Sig 355-3	Depot Inspection Standard for Moisture and Fungus Resistant Treatment
TM 43-0118	Field Instructions for Painting and Preserving Electronics Command Equipment, including Camouflage pattern painting of electrical equipment shelters.
TM 11-5820-670-12	Operator's and Organizational Maintenance Manual Including Repair Parts and Special Tool Lists' Radio Set AN/ARC-131.
TM 11-5821-284-20	Organizational Maintenance Manual: Blade Antenna AS-2285/ARC (NSN (5821-00-054-6374).
TM 11-6625-200-15	Operator's, Organizational, Direct Support, General Support, and Depot Maintenance Manual Multimeters ME-26A/U (NSN 6625-00-360-2493), ME-26B/U and ME-26C/U (6625-00-646-9781)
TM 11-6625-508-10	Operator's Manual' Signal General AN/USM-44 and AN/UMS-44A.
TM 11-6625-1610-12	Operator's and Organizational Maintenance Manual: Test Set, Antenna AN/ARM-115 (NSN 6625-00-035-4293).
TM 11-6625-1703-15	Operator's, Organizational, Direct Support, General Support and Depot Maintenance Manual: Oscilloscope AN/USM-281A (NSN 6625-00-228-2201).
TM 1-6625-2658-14	Operator's Organizational, Direct Support, General Support Maintenance Manual for Oscilloscope, AN/USM-281C (NSN 6625-00-106-9622).
TM 55-1500-323-25	Organizational, Direct Support, General Support, and Depot Maintenance Manual: Installation Practices for Aircraft Electric and Electronic Wiring
TM 38-750	The Army Maintenance Management System (TAMMS).

\* U. S. GOVERNMENT PRINTING OFFICE' 1982-505-028/39

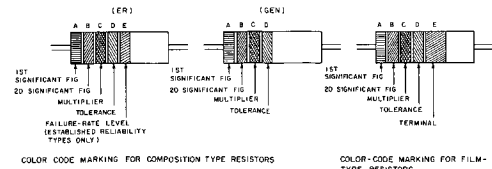
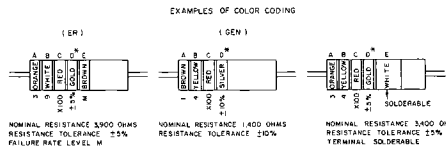

TABLE 1  
COLOR CODE FOR COMPOSITION TYPE AND FILM TYPE RESISTORS

BAND A		BAND B		BAND C		BAND D		BAND E	
COLOR	FIGURE	COLOR	FIGURE	COLOR	MULTIPLIER	COLOR	TOLERANCE (PERCENT)	COLOR	FAILURE RATE LEVEL
BLACK	0	BLACK	0	BLACK	1	BROWN	±10	BROWN	A1-D
BROWN	1	BROWN	1	BROWN	10	RED	±2	RED	B1-D
RED	2	RED	2	RED	100	ORANGE	±3	ORANGE	C1-D
ORANGE	3	ORANGE	3	ORANGE	1,000	YELLOW	±4	YELLOW	D1-D
YELLOW	4	YELLOW	4	YELLOW	10,000	SILVER	±5	WHITE	SOLD-ENABLE
GREEN	5	GREEN	5	GREEN	100,000	GOLD	±5		
BLUE	6	BLUE	6	BLUE	1,000,000	RED	±2 (NOT APPLICABLE TO ESTABLISHED RELIABILITY)		
PURPLE (VIOLET)	7	PURPLE (VIOLET)	7						
GRAY	8	GRAY	8	SILVER	0.1				
WHITE	9	WHITE	9	GOLD	0.1				

BAND A — THE FIRST SIGNIFICANT FIGURE OF THE RESISTANCE VALUE (BANDS A THRU D SHALL BE OF EQUAL WIDTH)  
 BAND B — THE SECOND SIGNIFICANT FIGURE OF THE RESISTANCE VALUE  
 BAND C — THE MULTIPLIER (THE MULTIPLIER IS THE FACTOR BY WHICH THE TWO SIGNIFICANT FIGURES ARE MULTIPLIED TO YIELD THE NOMINAL RESISTANCE VALUE)  
 BAND D — THE RESISTANCE TOLERANCE  
 BAND E — WHEN USED ON COMPOSITION RESISTORS, BAND E INDICATES ESTABLISHED RELIABILITY FAILURE RATE LEVEL (PERCENT FAILURE PER 1,000 HOURS). ON FILM RESISTORS THIS BAND SHALL BE APPROXIMATELY 1/2 THE WIDTH OF OTHER BANDS AND INDICATES TYPE OF TERMINAL RESISTANCES IDENTIFIED BY NUMBERS AND LETTERS (THESE ARE NOT COLOR CODED)  
 SOME RESISTORS ARE IDENTIFIED BY THREE OR FOUR DIGIT ALPHA NUMERIC DESIGNATORS THE LETTER A IS USED IN PLACE OF A DECIMAL POINT WHEN FRACTIONAL VALUES OF AN OHM ARE EXPRESSED FOR EXAMPLE  
 2R7 = 2.7 OHMS 10R0 = 10.0 OHMS

FOR WIRE-WOUND-TYPE RESISTORS COLOR CODING IS NOT USED. IDENTIFICATION MARKING IS SPECIFIED IN EACH OF THE APPLICABLE SPECIFICATIONS



COMPOSITION-TYPE RESISTORS  
 \* IF BAND D IS OMITTED, THE RESISTOR TOLERANCE IS ±20% AND THE RESISTOR IS NOT MIL-STD  
 A COLOR CODE MARKING FOR MILITARY STANDARD RESISTORS

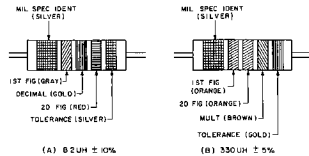

COLOR CODING FOR TUBULAR ENCAPSULATED R.F. CHOKES: AT A AN EXAMPLE OF THE CODING FOR AN 8 uH CHOKER IS GIVEN AT B, THE COLOR BANDS FOR A 330 uH INDUCTOR ARE ILLUSTRATED

TABLE 2  
COLOR CODING FOR TUBULAR ENCAPSULATED R.F. CHOKES

COLOR	SIGNIFICANT FIGURE	MULTIPLIER	INDUCTANCE TOLERANCE (PERCENT)
BLACK	0	1	
BROWN	1	10	1
RED	2	100	2
ORANGE	3	1,000	3
YELLOW	4		
GREEN	5		
BLUE	6		
VIOLET	7		
GRAY	8		
WHITE	9		
NONE		10	
SILVER		100	
GOLD		DECIMAL POINT	

MULTIPLIER IS THE FACTOR BY WHICH THE TWO COLOR FIGURES ARE MULTIPLIED TO OBTAIN THE INDUCTANCE VALUE OF THE CHOKER GOLD

B COLOR CODE MARKING FOR MILITARY STANDARD INDUCTORS

CAPACITORS, FIXED, VARIOUS-DIELECTRICS, STYLES CM, CN, CY, AND CB

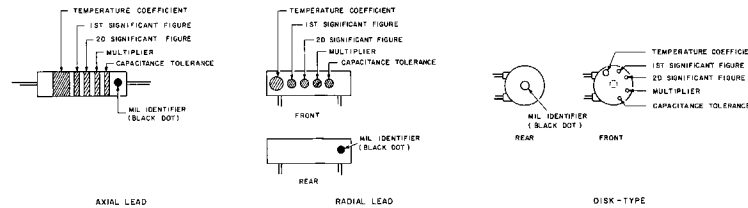
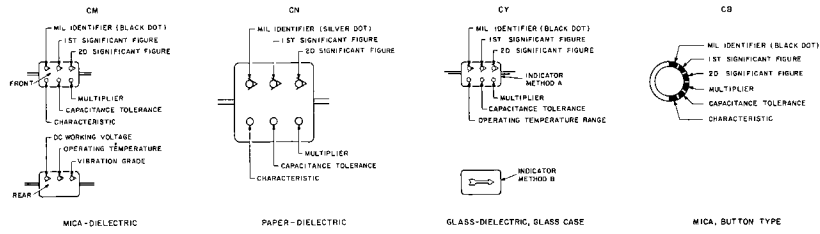

C COLOR CODE MARKING FOR MILITARY STANDARD CAPACITORS

TABLE 3 — FOR USE WITH STYLES CM, CN, CY AND CB

COLOR	MIL ID	1ST SIG FIG	2D SIG FIG	MULTIPLIER	CAPACITANCE TOLERANCE			CHARACTERISTICS	DC WORKING VOLTAGE	OPERATING TEMPERATURE RANGE	VIBRATION GRADE
					CM	CN	CY				
BLACK	CB	0	0	1		±20%	±20%	A	E	-55° to +70°C	0-25 Hz
BROWN		1	1	10				B	E		
RED		2	2	100	±1%	±2%	±2%	C	E	-55° to +100°C	
ORANGE		3	3	1,000	±10%	±20%	±2%	D	D	300	
YELLOW		4	4	10,000				E			±5% to +100% 10-2,000 Hz
GREEN		5	5		±5%			F		300	
BLUE		6	6								-55° to +100°C
PURPLE (VIOLET)		7	7								
GRAY		8	8								
WHITE		9	9								
GOLD				0.1	±10%	±10%	±10%				
SILVER	CM			0.01	±10%	±10%	±10%				

TABLE 4 — TEMPERATURE COMPENSATING, STYLE CC

COLOR	TEMPERATURE COEFFICIENT*	1ST SIG FIG	2D SIG FIG	MULTIPLIER	CAPACITANCE TOLERANCE OVER 10 uF	CAPACITANCE TOLERANCE 10 uF OR LESS	MIL ID
BLACK	0	0	0	1		±2.0 uF	CC
BROWN	-30	1	1	10	±1%		
RED	-60	2	2	100	±2%	±0.25 uF	
ORANGE	-150	3	3	1,000			
YELLOW	-220	4	4				
GREEN	-330	5	5		±5%	±0.5 uF	
BLUE	-470	6	6				
PURPLE (VIOLET)	-750	7	7				
GRAY		8	8	0.01*			
WHITE		9	9	0.1*	±10%		
GOLD	+100			0.1		±1.0 uF	
SILVER				0.01			

- THE MULTIPLIER IS THE NUMBER BY WHICH THE TWO SIGNIFICANT (SIG) FIGURES ARE MULTIPLIED TO OBTAIN THE CAPACITANCE IN uF
- LETTERS INDICATE THE CHARACTERISTICS DESIGNATED IN APPLICABLE SPECIFICATIONS MIL-C-5, MIL-C-280, MIL-C-11272B, AND MIL-C-10550C RESPECTIVELY
- LETTERS INDICATE THE TEMPERATURE RANGE AND VOLTAGE-TEMPERATURE LIMITS DESIGNATED IN MIL-C-10550C
- TEMPERATURE COEFFICIENT IN PARTS PER MILLION PER DEGREE CENTIGRADE
- OPTIONAL CODING WHERE METALLIC FINISHES ARE UNDESIRABLE

FO 6-1. Color code marking for MIL-STD resistors, inductors, and capacitors.

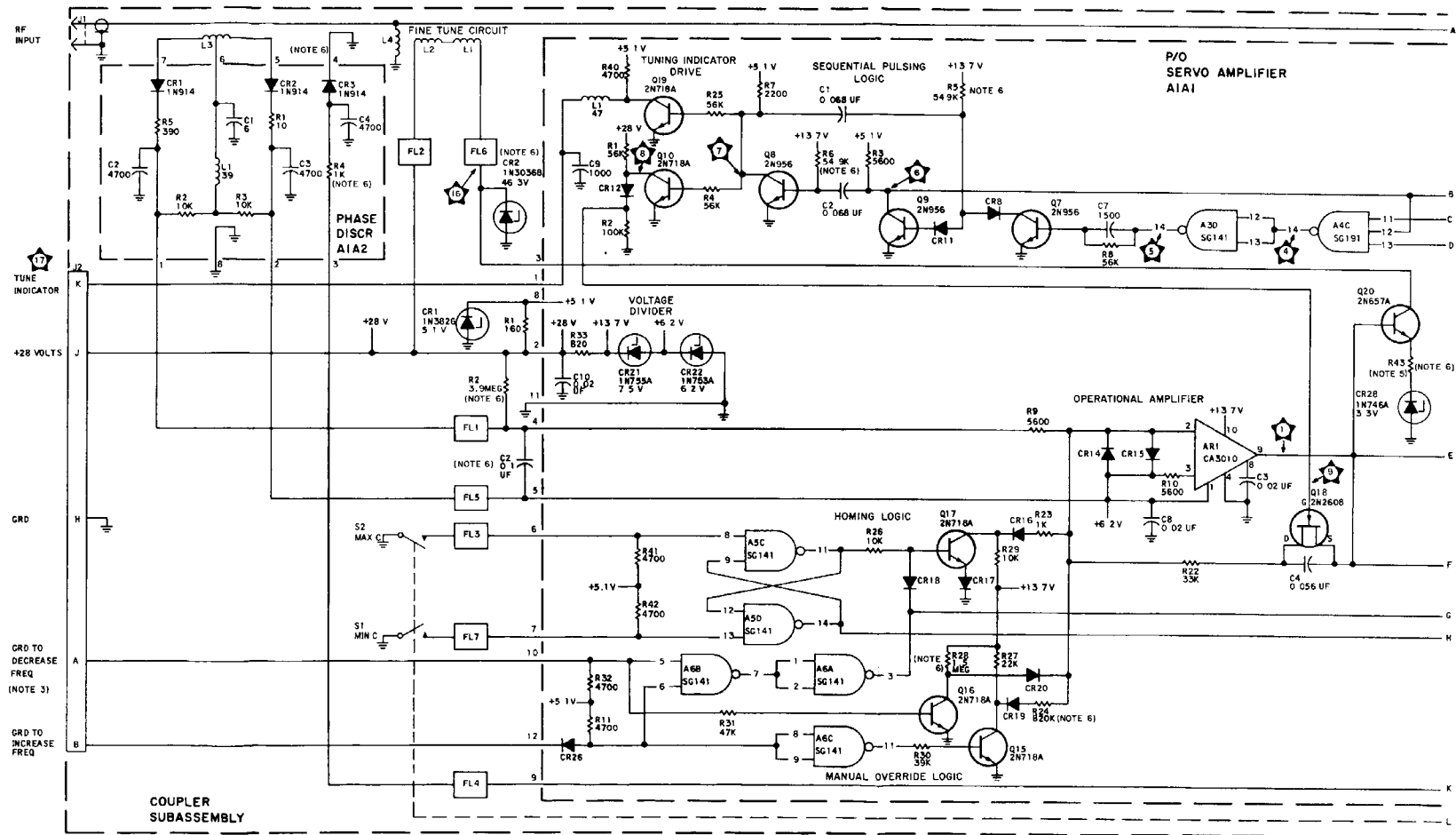

E L I J P 0 2 5

FO 6-2. 1. AS-2285/ARC and AS-2285A/ARC vhf/fm blade antenna (models 437S-1, -1A, -1C), schematic diagram.



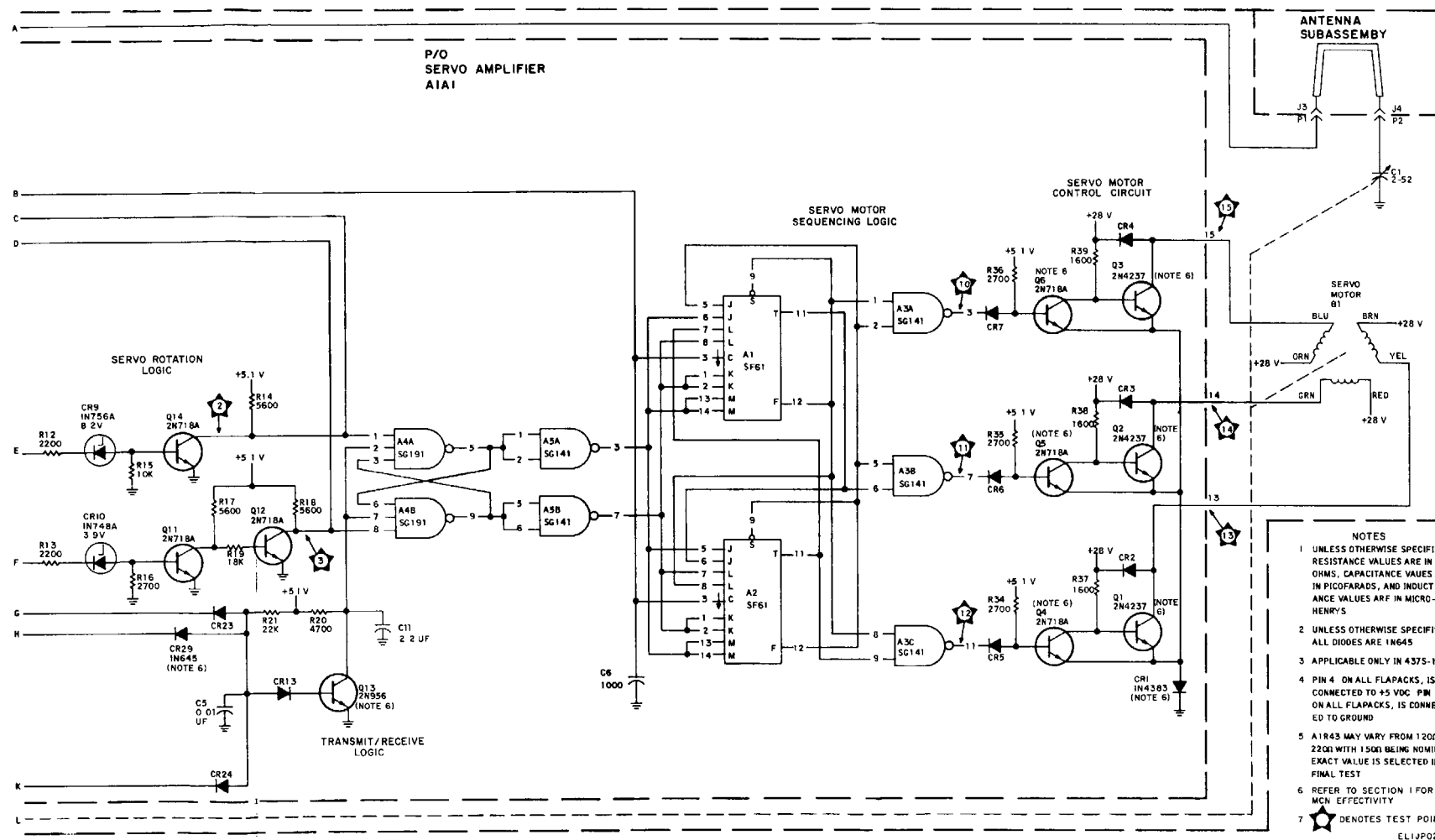

FO 6-2 . AS-2285/ARC and AS-2285A/ARC vhf/fm blade antenna (models 437S-1, -1B, ), schematic diagram.

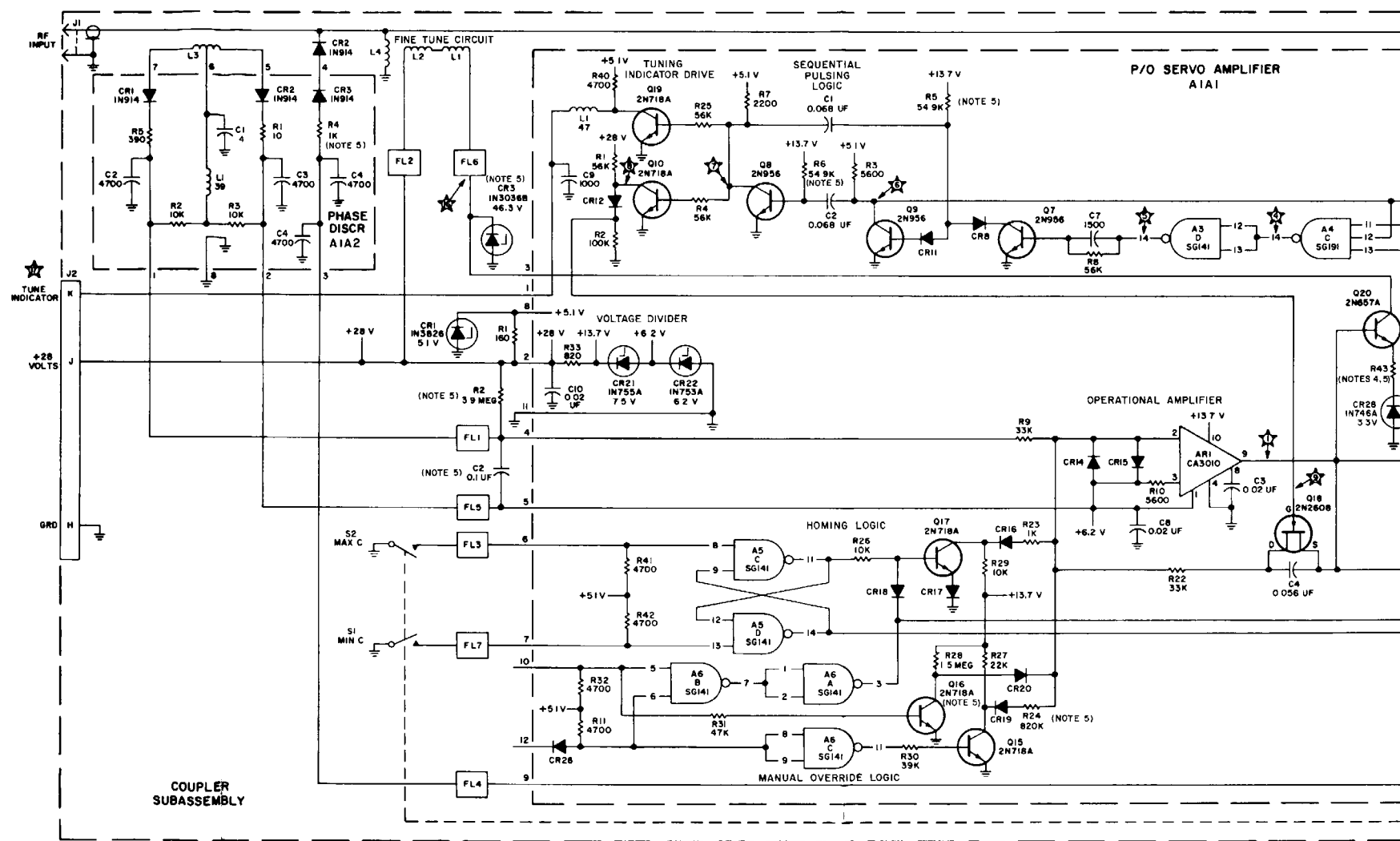

FO 6-3. 1. AS-2285/ARC vhf/fm blade antenna (models 437S-1B), schematic diagram.

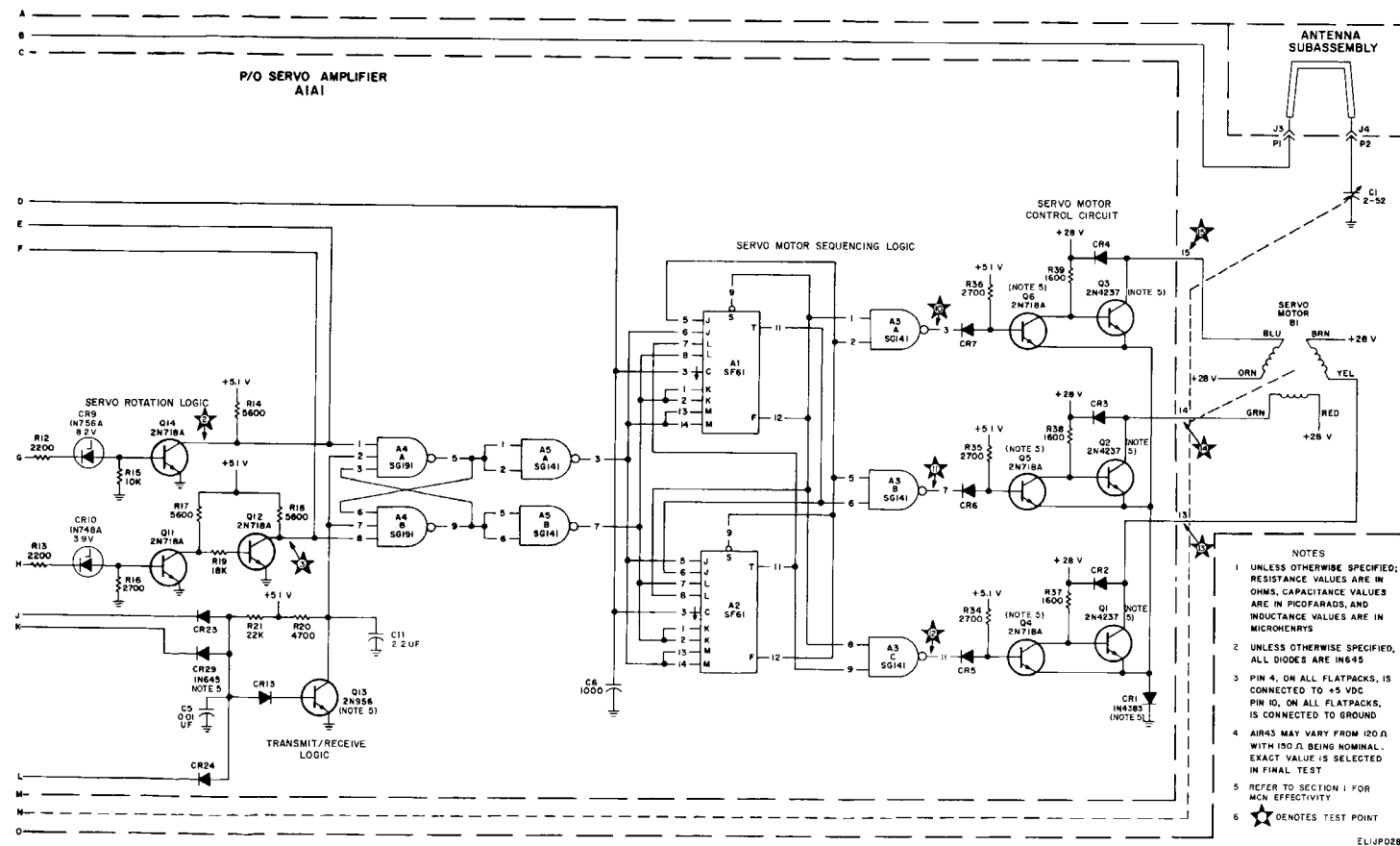

FO 6-3. 2. AS-2285/ARC vhf/fm blade antenna (models 437S-1B), schematic diagram.

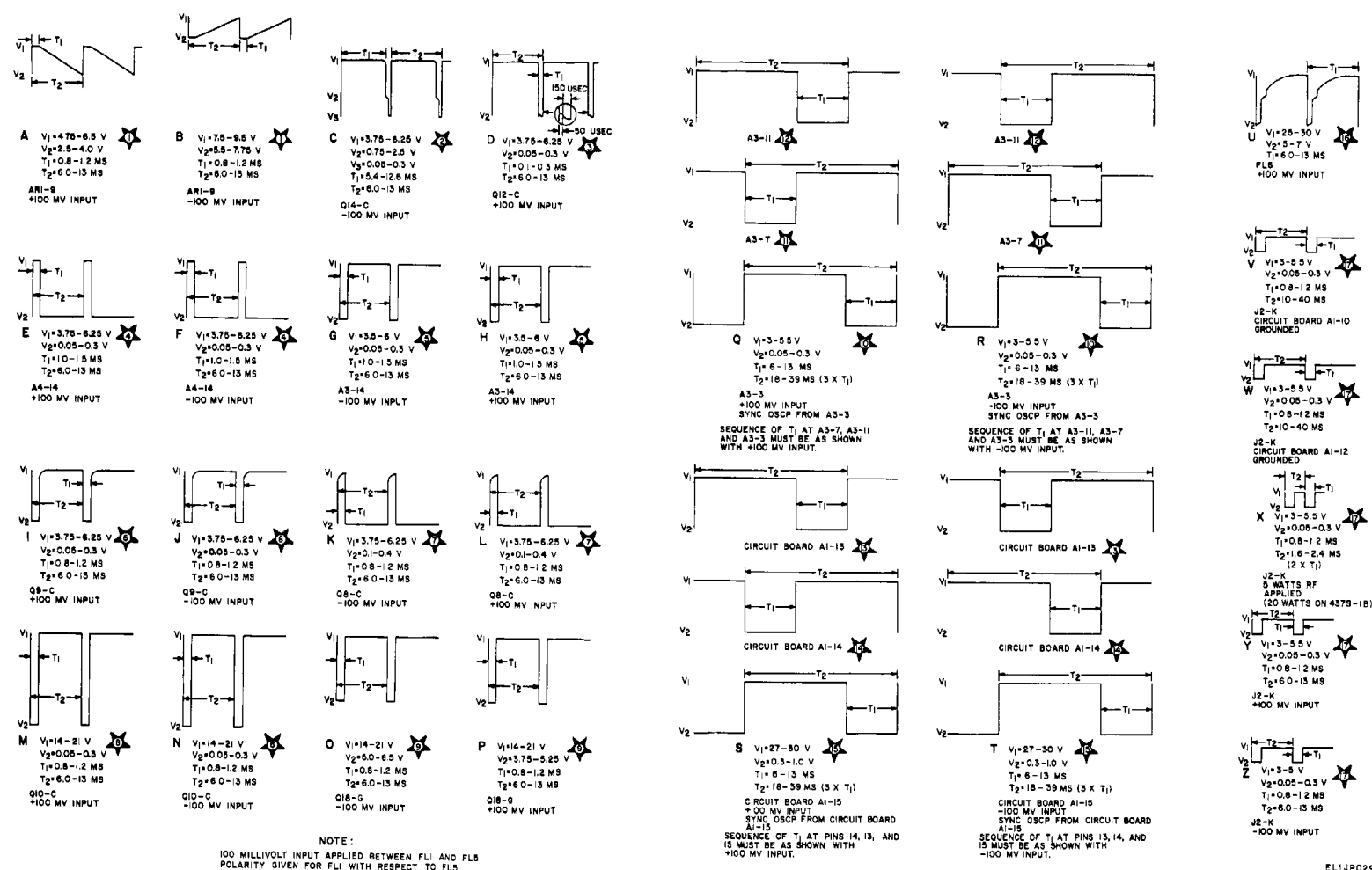

NOTE:  
 100 MILLIVOLT INPUT APPLIED BETWEEN FL1 AND FL5  
 POLARITY GIVEN FOR FL1 WITH RESPECT TO FL5

EL1JPO29

FO 6-4. AS-2285/ARC and AS-2285A/ARC vhf/fm blade antenna, waveforms.

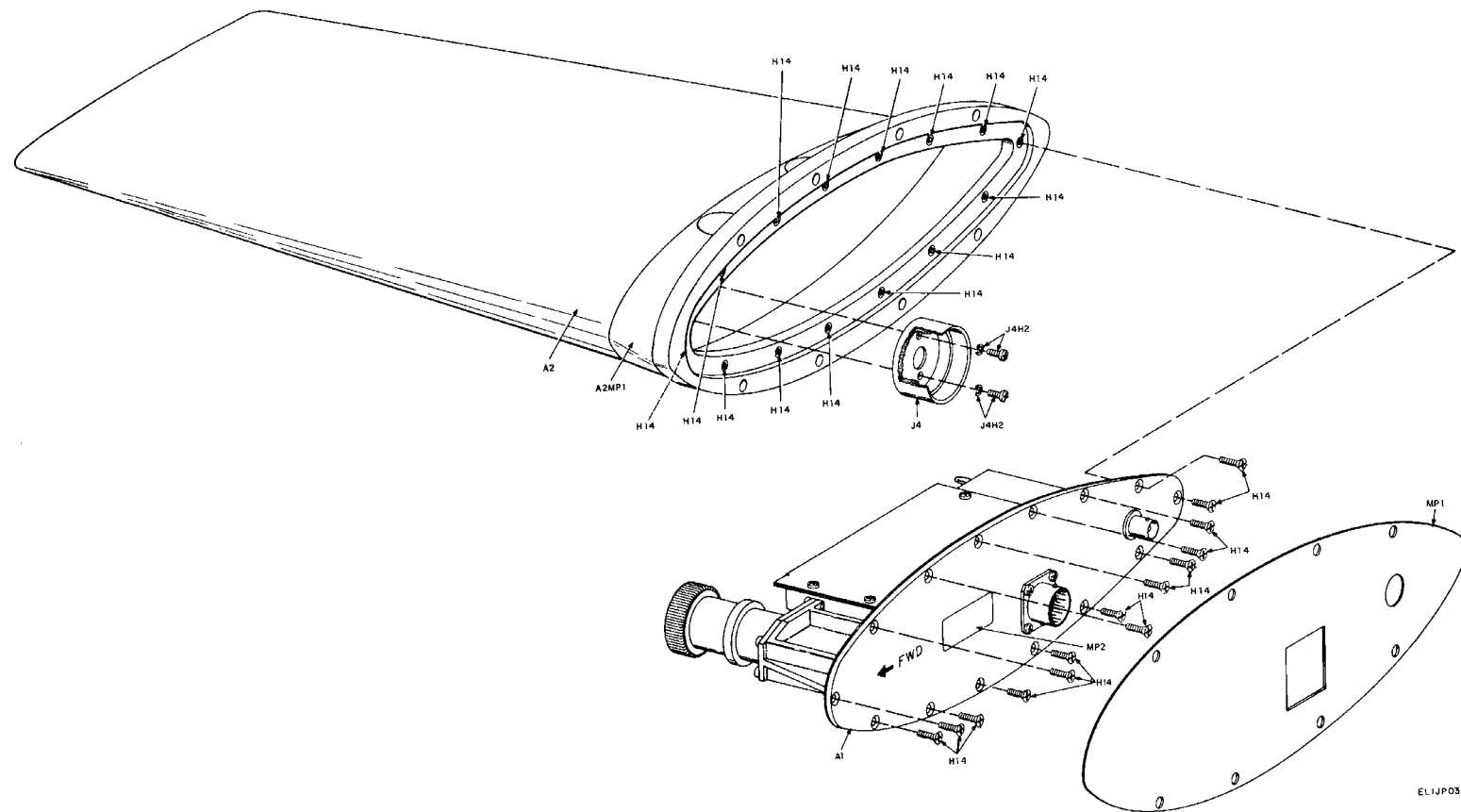

FO 6-5. Radome and coupler assembly, exploded view.





By Order of the Secretary of the Army:

E.C. MEYER  
General, United States Army  
Chief of Staff

Official:

ROBERT M. JOYCE  
Brigadier General, United States Army  
The Adjutant General

DISTRIBUTION:

To be distributed in accordance with DA Form 12-36, Direct and General Support maintenance requirements for AS-2285/ARC



**PIN: 051814-000**